

# USER MANUAL

## DPM / PEM Print & Apply System



## Content

### Please note -6

#### General notes -6

Validity of this manual and required compliance -6

How information is represented -7

#### For your safety -9

Intended use -9

Information and qualification -9

Operating safety of the machine -11

Every time before starting production -13

Warning notes on the machine -14

### Product description -16

#### Overview -16

Designs -16

Configurations -16

Functionality -16

Operating components -19

Control panel -21

Connections -22

#### Technical Data -24

Dimensions -24

Connection, device data -24

Pull-in / pull-out force -25

Label material -25

Performance data -26

Thermal transfer ribbon -29

Automatic ribbon economy -30

Mechanical features -32

Ambient conditions -32

Interfaces -33

Electronic equipment -33

Certificates and Markings -33

#### Options -35

External control panel -35

Connector for rotary encoder for APSF (DPM) -35

Centronics interface -35

RS232/422/485 interface -35

Ribbon core adapters -36

Pressure roller (DPM) -36

Long dispensing edge (DPM) -36

Deflection roller for vertical material feeding -36

- Operating modes **-37**
  - Overview **-37**
  - Online mode **-38**
  - Offline mode **-40**
  - Standalone mode **-43**
- Parameter menu **-44**
  - Overview of parameter menu **-44**
  - Information about the parameter description **-44**
  - PRINT PARAMETERS menu **-45**
  - SYSTEM PARAMETER menu **-47**
  - SPECIAL FUNCTION menu **-48**
  - SERVICE FUNCTIONS menu **-49**

## **Startup and Operation -50**

- Electrical connections **-50**
  - Connecting to the mains power supply **-50**
  - Connecting to a data host **-51**
  - Connecting sensors **-52**
- Inserting label material **-53**
  - Threading-in the label web (DPM) **-53**
  - Threading-in the label web (PEM) **-56**
- Inserting/replacing ribbon **-57**
  - Inserting ribbon **-57**
  - Changing ribbon **-58**
- Mechanical settings **-59**
  - Position the label sensor **-59**
  - Setting the ribbon tension **-60**
  - Setting the printhead pressure **-61**
- Switching on/off **-62**
  - Switching on **-62**
  - Switching off **-62**
- Setting and monitoring the machine **-63**
  - Settings in parameter menu **-63**
  - Monitoring functions **-64**
- Printing **-65**
  - Creating print jobs **-65**
  - Installing the printer driver **-65**
  - Transferring a print job **-65**
- Status messages **-67**
  - Error messages **-67**
  - List of error messages **-67**

## **Cleaning and Maintenance -69**

- Cleaning instructions **-69**
  - Safety **-69**
  - Cleaning agents **-69**
  - Cleaning interval **-69**

- General cleaning **-70**
- Printhead **-71**
  - General notes **-71**
  - Cleaning the printhead **-72**
  - Replacing printheads **-74**
  - Testing the printhead **-75**
- Rubber rollers **-76**
- Backing paper deviator roller (DPM) **-77**
- Sensors **-78**
  - Cleaning the punch sensor **-78**
  - Cleaning the material end sensor **-79**
- Cleaning the ribbon path **-80**
- Replacing the filter liner **-81**
- EU Declaration of Incorporation -82**
  - Appendix regarding the Declaration of Incorporation **-83**



# Please note

## GENERAL NOTES

### Validity of this manual and required compliance

#### Contents

The complete operating manual for the print & apply systems DPM and PEM consists of the following parts:

Manual	Target group	Medium	Availability
User manual	Operating personnel	Printed	Comes with machine
Installation manual		User-Docu-CD	
Service manual	Service personnel	Service-Docu-CD	Must be ordered separately <sup>a</sup>
Spare parts catalogue			

a) Only for certified and qualified service technicians or OEM partners.

This operating manual refers exclusively to the machine types listed above. It is used for proper operation and adjustment of the machine.

The machine must be properly installed and configured to allow for operation and settings.

For information about the required qualification, see section **Information and qualification**  on page 9.

For information about installation and configuration, see the service manual.

For technical questions not covered in this operating manual:

→ Follow the instructions of the service manual for the label dispenser

or

→ Request a service technician from our sales partner.

Our sales partner's customer service department is available especially for configuration settings and malfunctions.

#### Technical release

Technical release: 9/2014

Software version: 6.52

#### Liability

Novexx Solutions reserves the right:

- to make changes in design, parts and software and to use equivalent parts instead of those specified for the purpose of technological progress.
- to change information in this manual.

Any obligation to extend these changes to machines previously delivered is excluded.

#### Copyright

Novexx Solutions retains all rights to this manual and its appendices. Reproduction, reprint or any other type of duplication, including parts of the manual, are permitted only with written approval.

Printed in Germany

**Manufacturer**

Novexx Solutions GmbH  
 Ohmstrasse 3  
 D-85386 Eching, Germany  
 Tel.: +49-8165-925-0  
 Fax: +49-8165-925-231  
[www.novexx.com](http://www.novexx.com) 

**How information is represented****Explanation of symbols**

To enhance readability and make information easier to find, different types of information are identified:

- Instruction with no order of tasks assigned
  1. Numbered instructions introduced by preceding text
  2. The specified order must be followed!
- ▮▮▮ Special note for action that must be performed.
- ⊖ Explanation of an error cause in the reference of error messages.
  - Enumeration of features
  - Other feature



The Experts symbol identifies activities that are reserved exclusively for qualified and specially trained personnel.



The information symbol identifies notes and recommendations as well as additional information.

**Notes about hazards and risks**

Important instructions that must absolutely be followed are specially highlighted:

**WARNING!**

A warning symbol refers to risks that can result in severe or fatal injuries! The note contains safety measures to protect affected persons.

→ Instructions must be followed without exception.

**CAUTION!**

A caution symbol refers to risks that can result in property damage or personal injury (minor injuries). The note contains instructions for preventing damage.

→ Instructions must be followed without exception.

**Illustrations**

Illustrations appear in the text where required. References to these illustrations are shown in [square brackets] containing the number of the illustrations. Uppercase letters after an illustration number, for example [12A], refer to the corresponding item within the illustration.

Normally the machine is shown as the right version. The left version is only shown if there is a need to make a distinction.

**Key symbols**

Keys in the control panel are represented as text, for example "Press the ONLINE key".

**Parameters**

Parameters in the parameter menu are represented in the format MENU NAME > Parameter name in grey type.



## FOR YOUR SAFETY

### Intended use

Label *print dispense* modules of series DPM are designed for printing and dispensing self-adhesive labels using the direct thermal or thermal transfer procedure.

Label *print* modules of series PEM are designed for printing self-adhesive labels using the direct thermal or thermal transfer procedure.

The individual versions (DPM/PEM 4, DPM/PEM 5, DPM/PEM 6) differ in the maximum print width.

DPM and PEM designed for integration in a larger system, e. g. a packaging line. The modules are designed to fit into a frame, e. g. a cutout of a base plate. The handling and feeding of the label material has to be controlled externally. With the DPM, the rewinding of the backing paper has also to be controlled externally.

Various combinations of thermal transfer ribbons and label materials are used and must be available in the form of rolls.

The label material that is used must be punched, i.e. the self-adhesive labels adhere individually, separately by punchings, on a carrier material. The labels must only adhere strongly enough so that they will come loose when the material is deflected over a sharp edge.

Any other type of or more extensive application will be considered non-intended use.

NOVEXX Solutions shall assume no liability for damage resulting from non-intended use of the machine.

### Information and qualification

#### Ensuring the necessary qualification

- Only fully trained and authorised personnel are permitted to operate, adjust and maintain the machine.
- Service work must only be performed by qualified and appropriately trained technical specialists (service technicians) or the customer service department.
- Areas of responsibilities for operating and servicing the machine must be clearly defined and consistently observed.
- Personnel must also be regularly instructed in on-the-job safety and environmental protection.

#### Qualification for operation

The instruction provided for the operating personnel must ensure:

- that the operating personnel can use the machine independently and without danger.
  - that the operating personnel can rectify minor operating faults (for example a paper jam) independently.
- At least 2 persons should be instructed in operation.
  - Have a sufficient quantity of label materials available for tests and instruction.

#### Qualification for system integrators and service technicians



Knowledge required to install the print dispenser and perform service work must be demonstrated through appropriate qualification. Only service personnel with technical training are able to assess the tasks to be performed and recognise potential dangers.

- Knowledge acquired through technical training in mechanics and electronics (for example in Germany the training to become a mechatronics engineer).

- Participation in a technical training course for the corresponding label dispenser offered by the manufacturer.
- The service personnel must be acquainted with the functionality of the label dispenser.
- The system integrator must be acquainted with the functionality of the of the system into which the label dispenser is being integrated.

Tasks	System integrator	Operator	Service technician
Install the machine	X		
Connect	X		
Make settings	X		
Switch on/off	X	X	X
Insert/change material/ribbon	X	X	X
Application-related settings	X	X	X
Rectify minor operating faults <sup>a</sup>	X	X	X
Clean the machine		X	X
Rectify major operating faults <sup>b</sup>			X
Settings to the electronics/ mechanics			X
Repairs			X
 Manual:	Service manual, Installation manual	Operating Manual	Service manual, spare parts catalogue

[Tab. 1] An example of the distribution of tasks among different qualified personnel.

- a) For example faults when detecting labels
- b) For example incorrect labelling

**Making note of information**



**WARNING!**

The label dispenser can only be operated safely and efficiently by complying with all of the requisite information!

- Before beginning operation, read this operating manual and follow all of the instructions.
- Observe all additional safety and warning information given on the label dispenser.
- Only technically knowledgeable persons are permitted to operate the label dispenser and make settings on it.

Any product liability and warranty claims will not be valid unless the machine is operated according to the instructions in the operating manual.

**Keep product information at hand**

This operating manual

- must remain readily available for operating personnel at a location near to the machine
- must be kept in legible condition.
- If the machine is sold, it must be made available to the new owner.
- The safety and warning symbols and messages on the machine must be kept in a clean and legible state. Replace any signs that are damaged or missing.

## Operating safety of the machine

### Intended use

→ The machine must only be used in accordance with the specifications in section **Intended use** auf Seite 9.

### Warning of injuries due to electrical shock



**WARNING!**

This unit operates at mains voltage! Contacting electrically live components can cause lethal electrical shocks and burns.

The device is only completely disconnected from the mains if the power cable is unplugged.

→ Make sure the power supply socket is accessible.

→ In case of emergency, switch off the device and disconnect the power cable.

**Installation:**

→ Only operate the machine when the enclosure is properly installed.

→ The machine must only be connected by an authorised technician who is acquainted with the associated dangers.

→ The machine must only be connected with other machines if they meet the requirements of a SELV circuit (Safety Extra-Low Voltage circuit) in accordance with EN 60950.

→ Keep the machine's On/Off switch accessible.

**Cleaning:**

→ Before cleaning and maintenance, switch off the machine and pull out the main plug.

→ Keep the machine dry.

→ If a liquid gets into the machine, switch off the machine immediately and unplug the mains contactor. Notify a service technician.

**CAUTION!**

If the supply voltage is too high or too low, the machine may be damaged.

→ Only operate the unit at the mains voltage given on the type plate.

→ Ensure that the mains voltage set on the machine corresponds to the local mains voltage.

**Warning of injury hazards from mechanical components****WARNING!**

Danger of injury due to moving and rapidly rotating parts!

- Maintain a safety clearance from the machine when it is in operation.
- Never reach into a machine that is running.
- Switch off the machine before making any mechanical adjustments.
- Keep clear of the area around moving parts even when the machine is stopped if there is any possibility of the machine starting up.

Dancer levers work by spring tension and may snap back if the track tension of the label material suddenly decreases.

- Always keep clear of the range of motion of the dancer levers.

Entanglement hazard!

- When working in the vicinity of machines in operation, do not wear ties, loose clothing items, jewellery, wrist watches or similar objects on your body.
- Long hair must be kept in a hair net and must not be worn loose.

Crushing hazard on the dispensing edge (DPM) due to products on the conveyor equipment!

- If the machine is running or ready for operation, never reach between the product and the dispensing edge.
- Never remove or bypass the protective equipment to prevent reaching in while the machine is in operation.

Tripping hazard!

- Lay the connection cable and pneumatic hoses (if fitted) so that no one can trip over them.

## Every time before starting production

### Due diligence of the operator and service personnel

→ Ensure that the following requirements are met in accordance with details specified in the service manual:

- The machine must be set up and configured to meet applicable requirements.
- All necessary safety equipment must be installed.
- The machine must have successfully completed at least one test run.
- The machine must be connected to the energy supply.

→ Make the requisite personal protective equipment available to the operating personnel, for example hair nets. Ensure that the protective equipment is used properly.

### Due diligence of the operating personnel

- Check the safety equipment to ensure it is working correctly.
- Check the machine for visible damage. Report defects that are discovered immediately.
- Use personal protective equipment properly, for example wearing a hair net.
- Remove material and objects that are not required from the working area of the machine.
- Ensure that only authorised persons remain in the working area of the machine.
- Ensure that no one can be endangered by the machine starting up.

## Warning notes on the machine

### CAUTION!

Warning notes on the machine provide important information for the operating personnel.

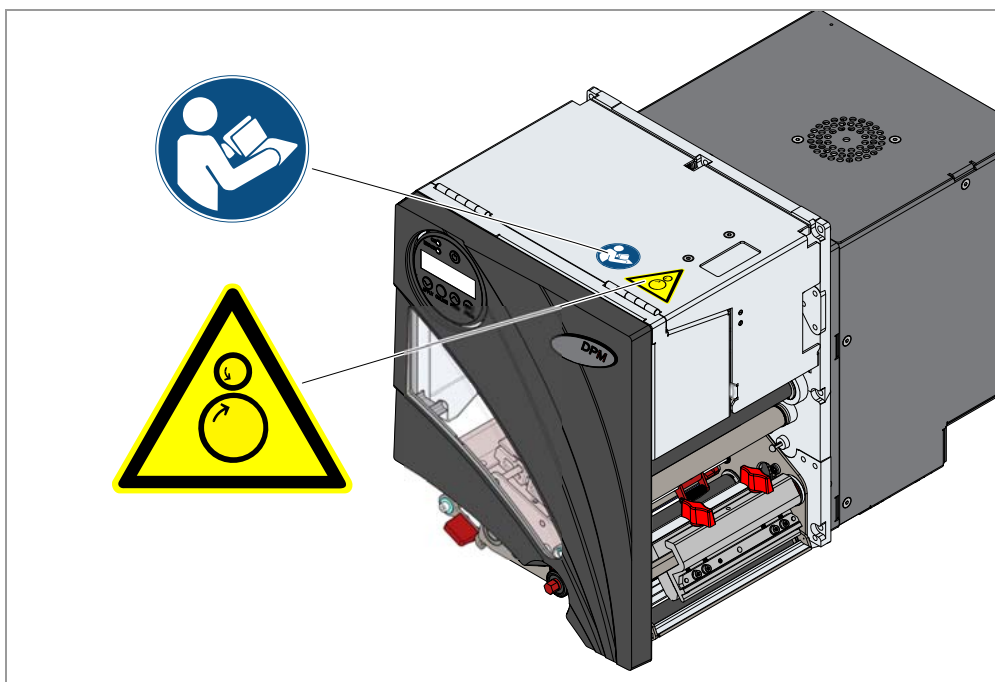

- Do not remove warning notes.
- Replace missing or illegible warning notes.

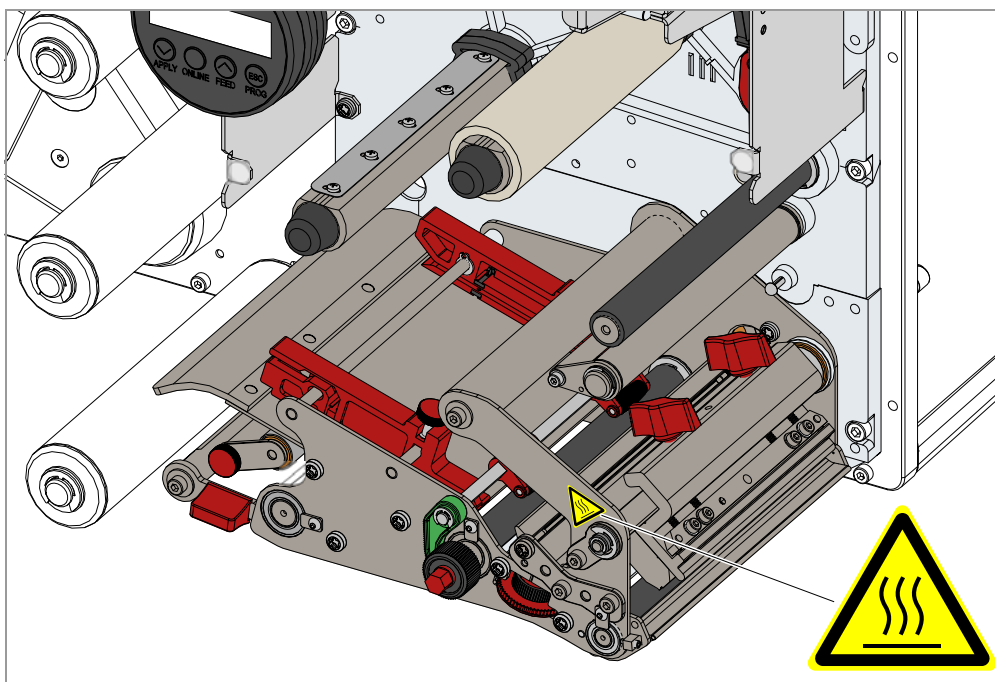

[1] Warning notes on the DPM/PEM (fig.: DPM)



[2] Warning notes on the DPM/PEM (fig.: PEM)

Warning note	Meaning	Article no.
	The 'Pinch point' warning note warns you of the danger posed by the machine's rotating parts; they can trap items and draw them in.	A5346
	The "Hot surface" symbol warns of a burn hazard if the surface is touched. Allow the device to cool off before touching it.	A5640
	The blue label 'Read manual' demands that operators read the user manual.	A5331

[Tab. 2] Meaning of the warning notes.

# Product description

## OVERVIEW

### Designs

The print & apply systems DPM (Dispensing Print Module) and PEM (Print Engine Module) are available in versions DPM/PEM 4, DPM/PEM 5 and DPM/PEM 6. These versions differ in the width of the printhead:

- DPM/PEM 4: 4" print width (106 mm)
- DPM/PEM 5: 5" print width (127 mm)
- DPM/PEM 6: 6" print width (160 mm)

### RH/LH

Each machine of series DPM/PEM is available as a right-hand (RH) or left-hand (LH) version [3]:

- DPM/PEM RH: The label exits the machine on the *right*.
- DPM/PEM LH: The label exits the machine on the *left*.

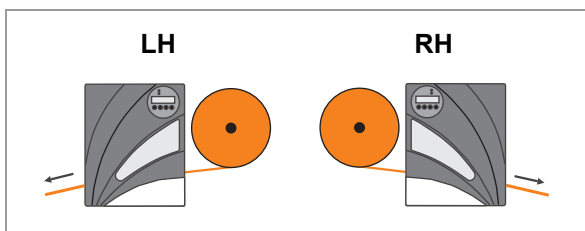

[3] DPM/PEM LH and RH.

### Configurations

DPM/PEM modules can be adjusted in many ways to meet customer requirements:

Feature	Adjustment
Direction in which products move	Selection of design: LH / RH
Assembly position of the machine	Horizontal / vertical (for labelling from above or from the side)
Label application	Direct dispensing or by means of an applicator

[Tab. 3] Options for configuring the DPM/PEM.

### Functionality

DPM and PEM both are modules. To be able to function, they must be integrated in a system surrounding, which feeds label material in an appropriate manner and leads away used backing material (DPM) respectively printed label material (PEM).

#### DPM

The main function of the DPM is printing, dispensing and applying self-adhesive labels. The printing is done using the thermal or thermal transfer process. „Dispensing“ means separating the label from the backing paper. The dispensing is done by pulling the label web around a (dispensing) edge with small radius. Applying the label is done directly after the dispensing edge by means of a pressure roller.

Sequence of print dispensing:

- A print job is transferred to the printer (via data interface or memory card). Afterwards, the machine is ready to print.
- The machine prints and dispenses a label as soon as a start signal arrives (coming e. g. from an external product sensor at a conveyor). The label is attached directly off the dispensing edge onto the product by means of a pressure roller [4].

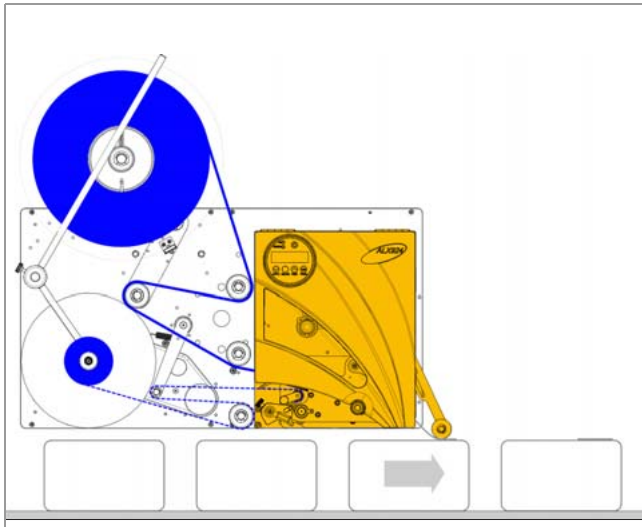

[4] DPM integrated in an ALX 92x print dispenser, which feeds the material and rewinds the backing material.

## PEM

The main function of the PEM is printing with high speed on cardboard or self-adhesive labels. The printing is done using the thermal or thermal transfer process. The printed label material is typically further processed as follows:

- Buffering the printed material in a loop. A downstream unit, which is coupled with the PEM, dispenses and applies the labels. Typical application: Print & Apply machine of the ALX 73x type [5].
- Winding up the printed material. The roll of printed material is inserted into a label dispenser that dispenses and applies the labels independently of the print process.

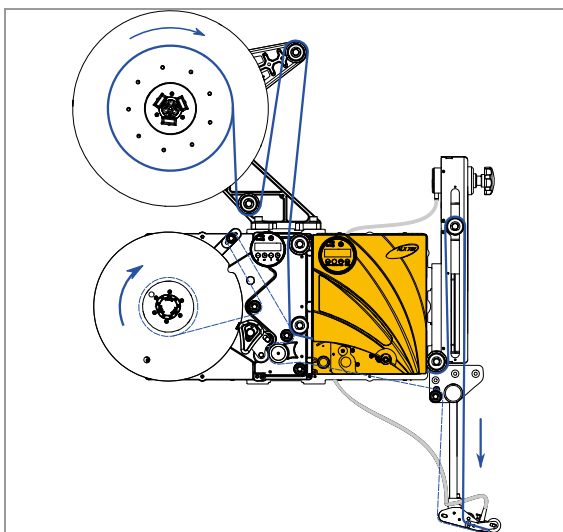

[5] PEM integrated into print & apply machine of the ALX 73x type.





[6] Application with two PEM modules for two colour printing. Between the two modules is a buffer loop. At the left side, the printed material is wound up.

## Operating components

### DPM

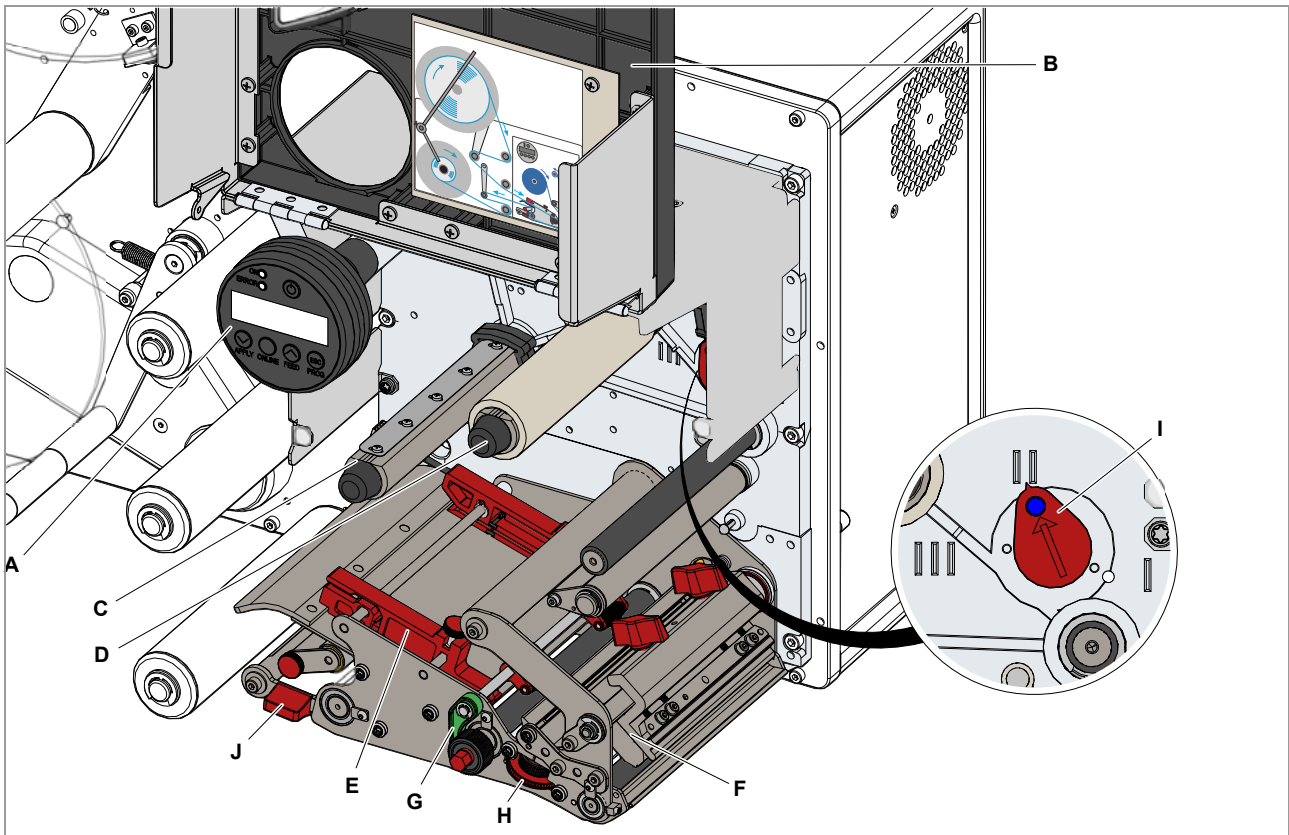

[7] Operating parts of the DPM (here: integrated part of an ALX 92x).

- A** Control panel  
Displays the device operating status; for defining settings in the parameter menu.
- B** Front cover  
Held open by gas pressure spring. Inside: Insert diagram showing the path of the labelling material and ribbon.
- C** Ribbon unwinding mandrel  
Holds the ribbon roll.
- D** Ribbon winding mandrel  
Winds up the used ribbon.
- E** Material guides  
The material end sensor is located inside the material guide.
- F** Printhead
- G** Pressure lever
- H** Adjustment wheel for label sensor
- I** Adjustment knob for printhead pressure
- J** Locking lever for pressure roll at the feed roller

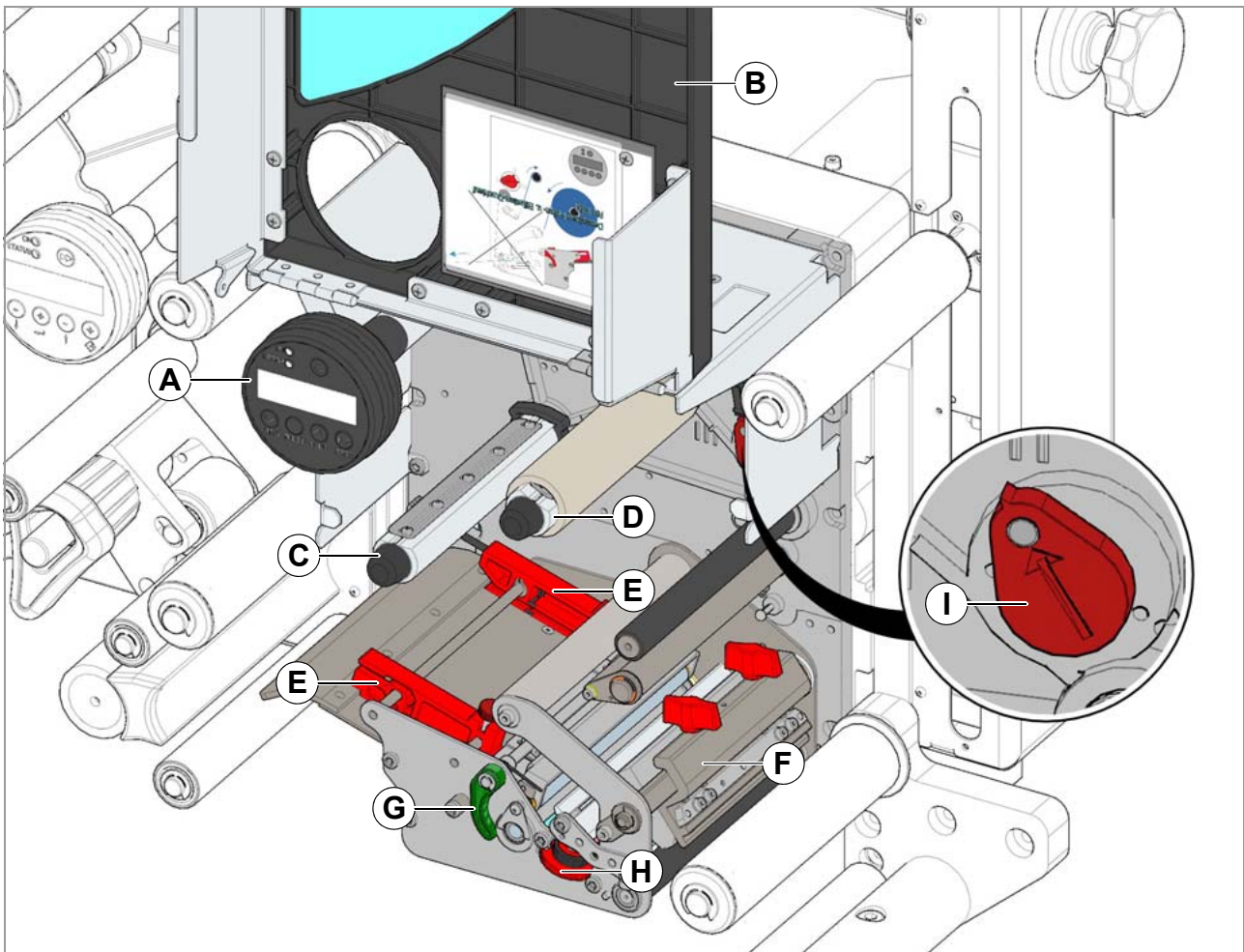
**PEM**

[8] Operating parts of the PEM (here: integrated part of an ALX 73x).

- A** Control panel  
Displays the device operating status; for defining settings in the parameter menu.
- B** Front cover  
Held open by gas pressure spring. Inside: Insert diagram showing the path of the labelling material and ribbon.
- C** Ribbon unwinding mandrel  
Holds the ribbon roll.
- D** Ribbon winding mandrel  
Winds up the used ribbon.
- E** Material guides  
The material end sensor is located inside the material guide.
- F** Printhead
- G** Pressure lever
- H** Adjustment wheel for label sensor
- I** Adjustment knob for printhead pressure

## Control panel

Different languages are available for texts that appear on screen. Instructions for selecting the language: See chapter **Settings in parameter menu** □ on page 63.

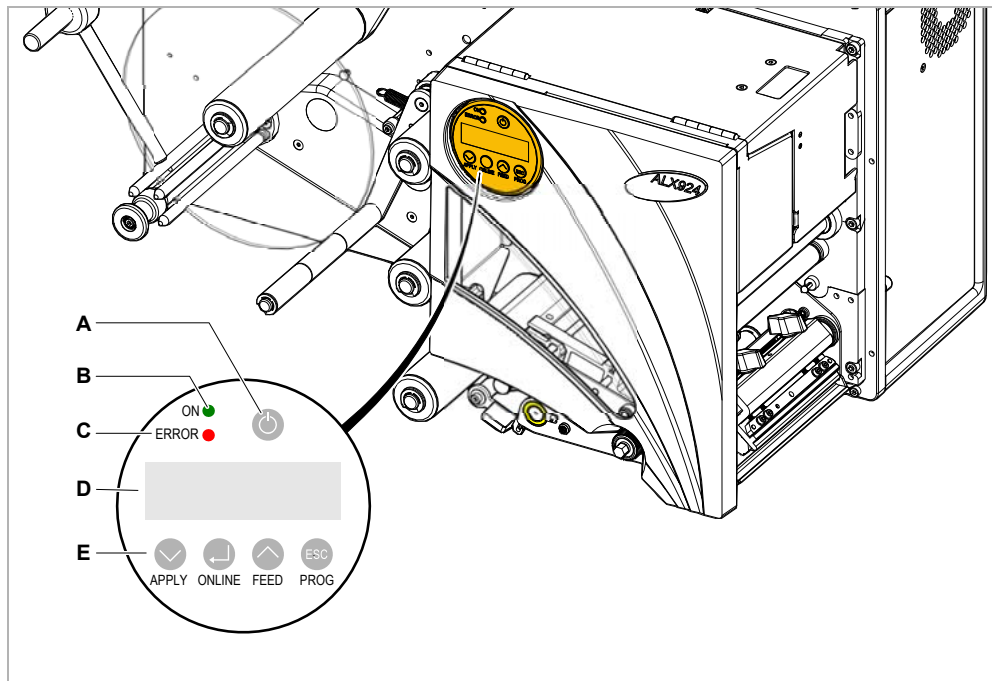

[9] Control panel at the DPM.

### A On/Off switch

Switches the printer on and off. To do this, press this button for longer than 2 seconds. Requirement: The mains power switch is turned on (position "I").

### B Operating LED

Lights up green when the printer is turned on.

### C Error LED

Lights up red when an error has occurred.

### D Screen

Display of operating states, parameters, setting values and error messages. The displays depend on the operating state of the printer. They are described in chapter **Operating modes** □ on page 37.

### E Keys

The functions of the keys depend on the operating state of the printer. They are described in chapter **Operating modes** □ on page 37.

## Connections

**WARNING!**

Danger of electrocution.

→ Only connect the printer to devices that fulfil the SELV (safety extra-low voltage) circuit requirements in accordance with EN 60950.

**CAUTION!**

Danger of damage to the machine due to faulty accessories.

→ Only connect original accessories.

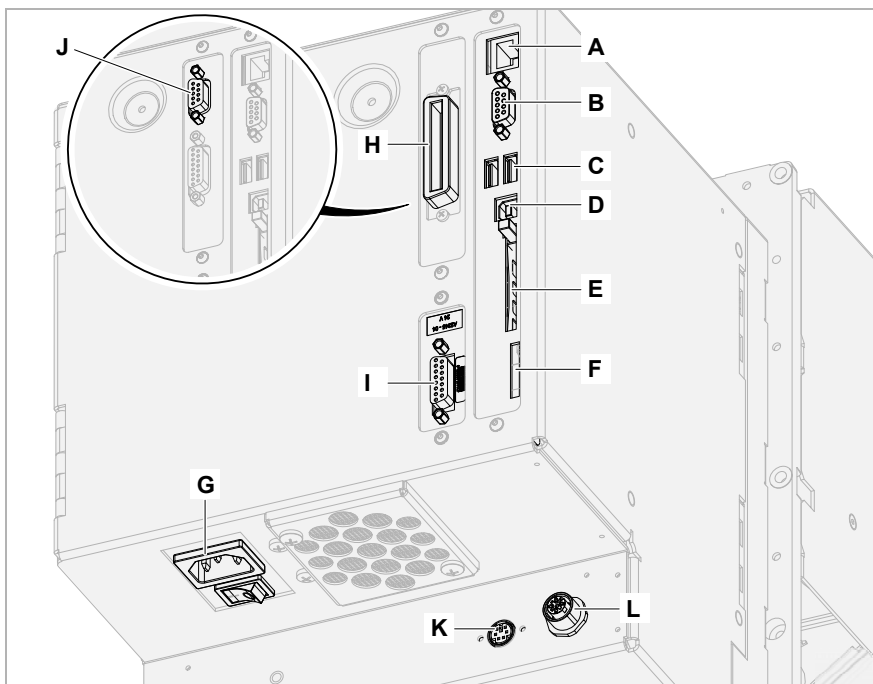

[10] Connections on a DPM.

- A** *Network connection* (Ethernet 10/100); used to transfer print jobs from a host; read service data; transfer firmware; operation via web server
- B** *Serial interface* (RS232); used to transfer print jobs from a host; read service data; transfer firmware
- C** *USB device interfaces* (2x); used to connect devices, for example keyboard or scanner
- D** *USB interface type A* (host); used to transfer print jobs from a host; read service data; transfer firmware
- E** *Card slot for CompactFlash cards*; used to store/load print jobs, service data or firmware
- F** *Card slot for SD/MC cards*; used to store/load print jobs, service data or firmware
- G** Connection to the *mains power supply*
- H** (Option) *parallel interface* (Centronics); used to transfer print jobs from a host; read service data; transfer firmware
- I** *Signal interface* (USI); optionally with 5 V or 24 V signal voltage; used to trigger the print-(dis-)process (start signal); controlling of applicators or scanners; querying the machine status
- J** (Option) *Serial interface* (RS232 or RS422 or RS485); used to transfer print jobs from a host; read service data; transfer firmware

- K** (Option) Connection for rotary encoder for automatic speed adaption (APSF)
- L** (Option) Connection for *external operator panel* (see )  
Anschluss für ein *externes Bedienfeld* (siehe **External control panel**  auf Seite 35)

## TECHNICAL DATA

### Dimensions

#### Dimensions

Dimensioned drawings of the ALX 92x in DXF format (Autocad) can be found on the Documentation-CD in directory „\Dimensional Drawings“.

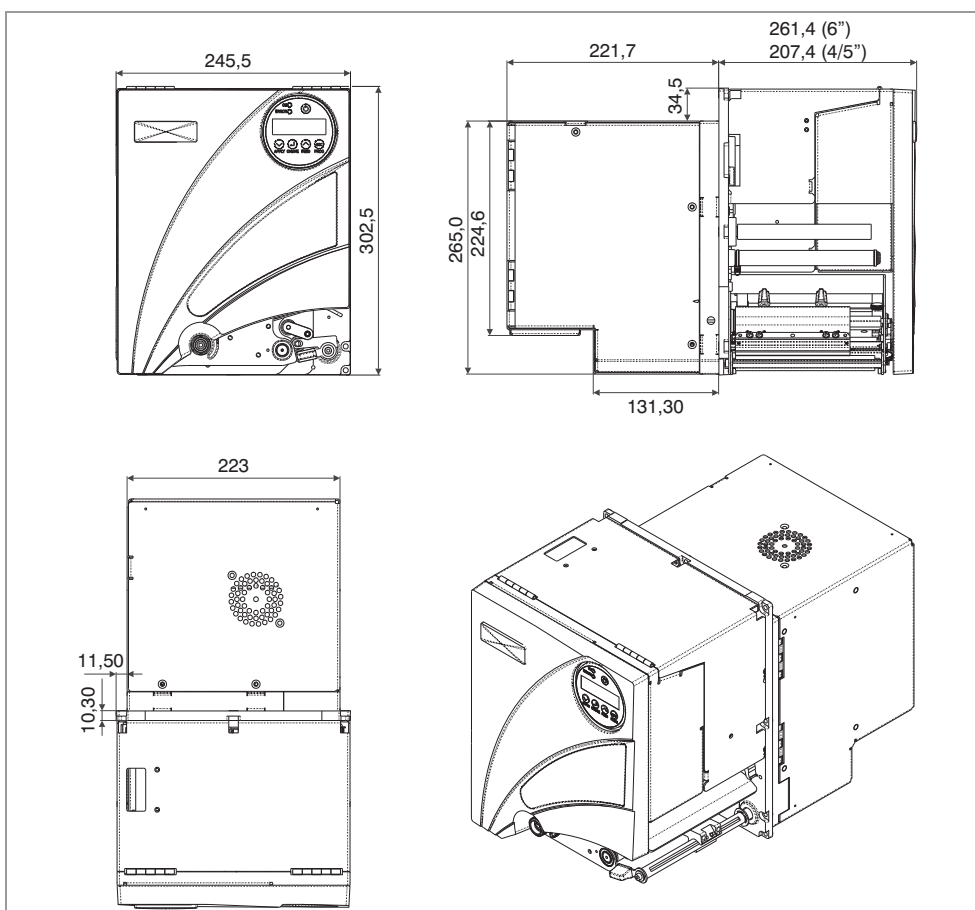

[11] Dimensions of the DPM/PEM (LH-version).

#### Weight

Machine	Weight
DPM/PEM 4"/5"	17 kg
DPM/PEM 6"	18 kg

[Tab. 4] Weights of the DPM and PEM.

### Connection, device data

#### Protection category

I

#### Mains voltage

100-240V (AC)

**Mains frequency**

60/50 Hz

**Power consumption**

450W

**Input current**

3.5-1.5 A

**Pull-in / pull-out force**

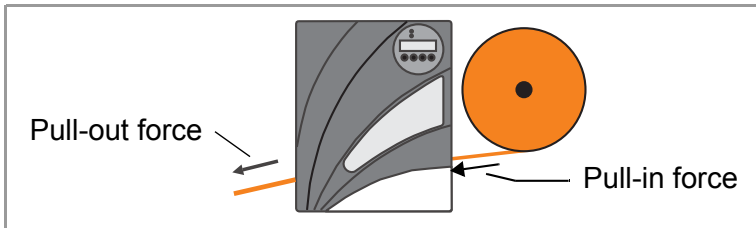

[12] Pull-in / pull-out force, schematic.

- ▣ The maximum difference between pull-in and pull-out force may be 9 N.
- ▣ The pulling forces in the label web must be applied evenly.

Example: The unwinder brakes with 10 N. Then, the rewinder may pull with a force in the range of 1 to 9 N (given that the backing paper is strong enough not to tear off).

**Label material**

**Material types**

- *DPM*: All common self-adhesive labelling materials, suitable for printing in thermal direct and thermal transfer process.
- *PEM*: All common self-adhesive, cardboard<sup>1</sup> or plastic<sup>2</sup> labelling materials, suitable for printing in thermal direct and thermal transfer process.

**Material measures**

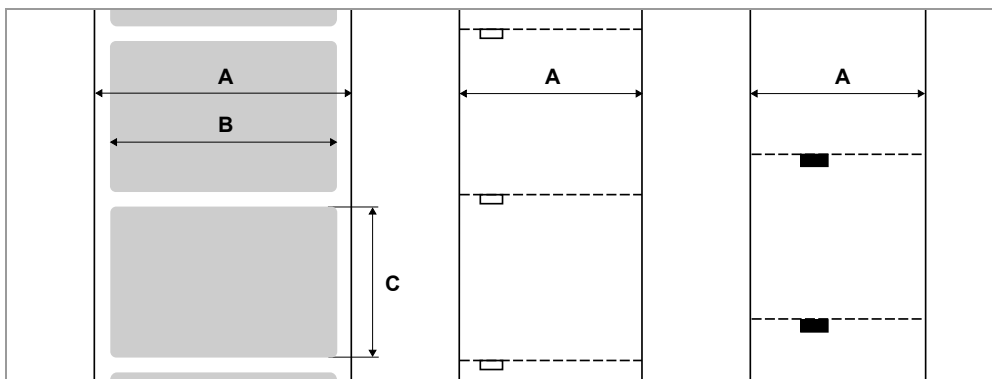

[13] Material measures:  
**A** Material width  
**B** Label width  
**C** Label length

1) up to 240 g/m<sup>2</sup>  
 2) PE, PP, PVC, PA



Machine	Material width	Label length
DPM/PEM 4/5	16-136	5-1000
DPM/PEM 6	16-190	

[Tab. 5] Label measures in mm.

**Punches / Black marks**

Only the PEM can process label material with black marks (on the bottom side).

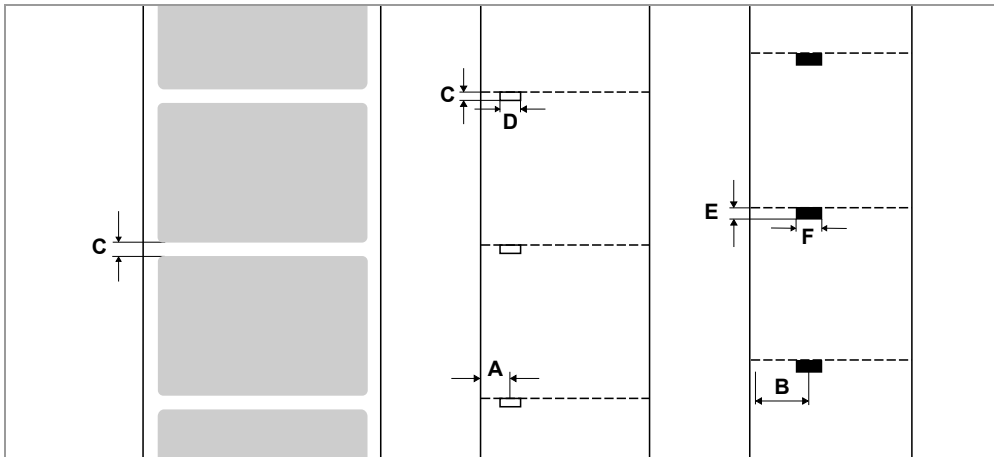

[14] Punches and black marks at different material types.

- A Punch position
- B Black mark position
- C Punch length
- D Punch width
- E Black mark length
- F Black mark width

Machine	Punch pos. [14A]	Punch length [14B]	Punch width [14C]
DPM/PEM 4/5	2-80 mm	0.8-14 mm	min. 4 mm
DPM/PEM 6	2-100 mm		

[Tab. 6] Measures of punches

Machine	Position [14B]	Length [14E]	Width [14F]
PEM 4/5	2-80 mm	4 mm	min. 12 mm
PEM 6	2-100 mm		

[Tab. 7] Measures of black marks

**Performance data**

**Print head**

- *Print technology:* Thermal direct or thermal transfer printing
- *Print head type:* "Corner Edge"

- *Print head characteristics:*

Printer	Resolution (dots/mm)	Resolution (dpi)	Max. print width (mm)
DPM/PEM 4	12.0	300	104
DPM/PEM 5			127
DPM/PEM 6			160

[Tab. 8] Printhead variables.

**Print speed**

Machine	Print speed (mm/s)	Print speed (inch/s)
DPM/PEM 4	50-400	2-16
DPM/PEM 5		
DPM/PEM 6	50-300	2-12

[Tab. 9] Printspeed overview.

Speed control: Fixed setting or automatic speed adaption via a rotary encoder (connector = option).

**Label sensor**

Self-initializing *light-transmission sensor* for punched label material.

(PEM only) Additional *black mark sensor* below the material web.

Setting range [15c]:

- DPM/PEM 4/5: 2-80 mm
- DPM/PEM 6: 2-100 mm

Recommended punch dimensions see chapter **Punches / Black marks** on page 26.

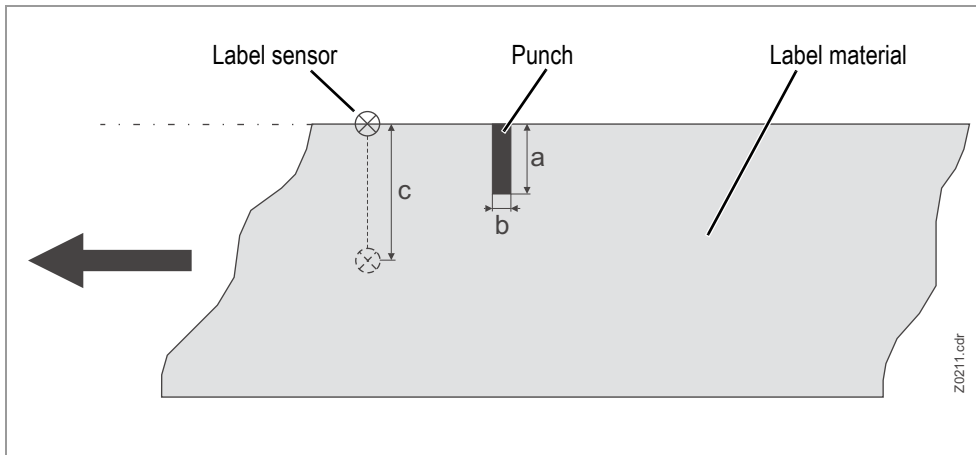

[15] Adjustment range of the label sensor.

**Max. print length**

The maximum print length depends on the following factors:

- Printer type
- Printer resolution
- Firmware version
- Parameter settings for memory configuration (for example SYSTEM PARAMETER > Free store size)

**Impression accuracy**

- In printing (y-) direction:

The impression accuracy depends on the print position. With the printout starting directly at the punch position, the accuracy is  $\pm 0.5$  mm. A distance between punch (that is label start) and print position will add  $\pm 1\%$  of this distance to the accuracy fault [16].

- X-direction:  $\pm 0.5$  mm.

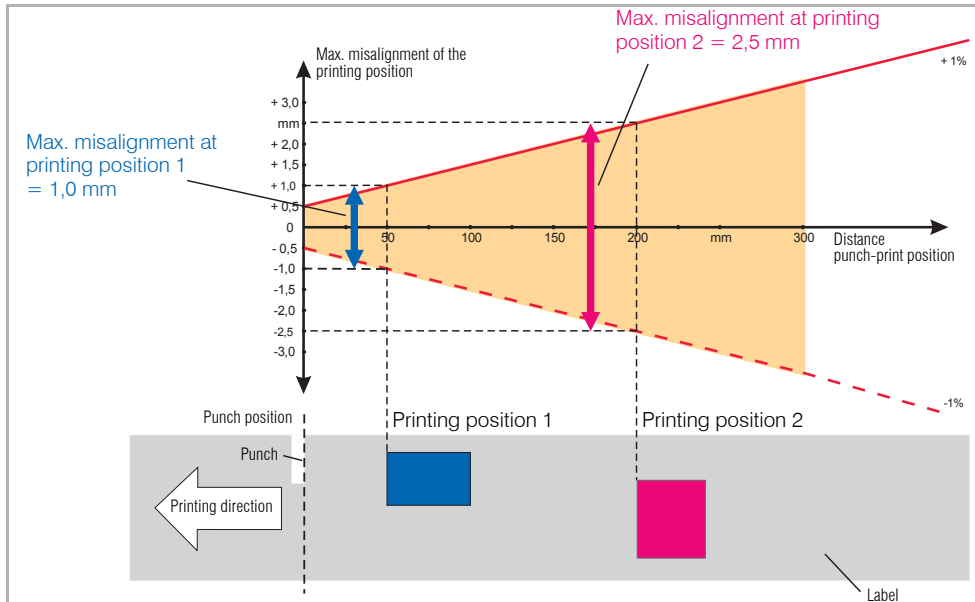

[16] Impression accuracy in printing direction, depending on the printing position.

**Output modes**

1:1 and 100% printable.

Non-printable areas:

- 1 mm from the front label edge (1st edge in feed direction)
- 1 mm from the left band border (right border in feed direction)

**Interpreter**

Easy Plug, Line Printer, Hex Dump

**Character sets**

- 17 character sets with fixed size (fixedfonts) including OCR-A and OCR-B
- 3 Scalable character set (speedo fonts)
- TrueType character sets are supported (in Unicode as well)
- TrueType, speedo and fixed size fonts can be optionally stored on a memory card

**Character modification**

- Scaling in X/Y direction up to factor 16
- Rotation:
  - Resident fonts, bar codes, lines and graphics: 0, 90, 180, 270 degrees
  - Truetype fonts: 0 to 359.9 degrees

**Bar codes**

Codabar	Code 128 A, B, C
Code 128	Code 128 UPS
Code 128 pharmacy	ITF
Code 2/5 matrix	MSI
Code 2/5 interleaved	EAN 13 add-on 2
Code 2/5 5-line	EAN 13 add-on 5
Code 2/5 interleaved ratio 1:3	EAN 128
Code 2/5 matrix ratio 1:2,5	Postcode (guide and identity code)
Code 2/5 matrix ratio 1:3	UPC A
Code 39	UPC E
Code 39 extended	Code 93
Code 39 ratio 2,5:1	
Code 39 ratio 3:1	

All bar codes scalable in 30 different width and in the height.

**2-dimensional bar codes**

Data Matrix Code (code according to ECC200)
Maxi Code
PDF 417
Codablock F
Code 49
QR Matrix Code

**GS1 Databar & CC bar codes**

Reduced Space Symbology (GS1 Databar) und Composite Component (CC) bar codes:

GS1 Databar-14	UPC-A + CC-A/CC-B
GS1 Databar-14 truncated	UPC-E + CC-A/CC-B
GS1 Databar-14 stacked	EAN 13 + CC-A/CC-B
GS1 Databar-14 stacked omnidirectional	EAN 8 + CC-A/CC-B
GS1 Databar limited	UCC/EAN 128 + CC-A/CC-B
GS1 Databar expanded	UCC/EAN 128 + CC-C

**Thermal transfer ribbon****Ribbon type**

The following recommendations are given for thermotransfer ribbons:

- The ribbon reverse must have an anti-static and friction-reducing coating (backcoating).
- Ribbons must be specified for "Near Edge Type" print heads.
- Ribbons should be suitable for print speeds of up to 12 inch/sec.

**Roll**

Variable	Dimension
Outer Ø	max. 110 mm <sup>1</sup>
Core inside Ø	25.4 mm (1")
	40.2 ± 0.2mm (1.6") <sup>2</sup>
Width <sup>3</sup>	20 -140 mm

[Tab. 10] Dimensions of usable ribbon rolls.

- 1) Corresponds to 1000 m standard ribbon type NOVEXX Solutions 10297-1000-xx with a ribbon core of 40.2 mm.
- 2) With ribbon core adapter (accessory)
- 3) As a general rule, the thermal transfer ribbon must overlap the label being printed on both sides by 2 mm.

**CAUTION!** - If huge ribbon rolls (run length of 1000m) are used with activated ribbon saving function, there is a hazard of the ribbon tearing off.  
 → Consider the limitations according to (Tab. 12) and (Tab. 13)!

**Automatic ribbon economy**

In regular print mode, ribbon is fed simultaneously with the labelling material. The automatic ribbon economy (= „ribbon saving“) stops the feeding of the ribbon if there are label areas of a certain size without imprinting. As a result, ribbon is saved [17].

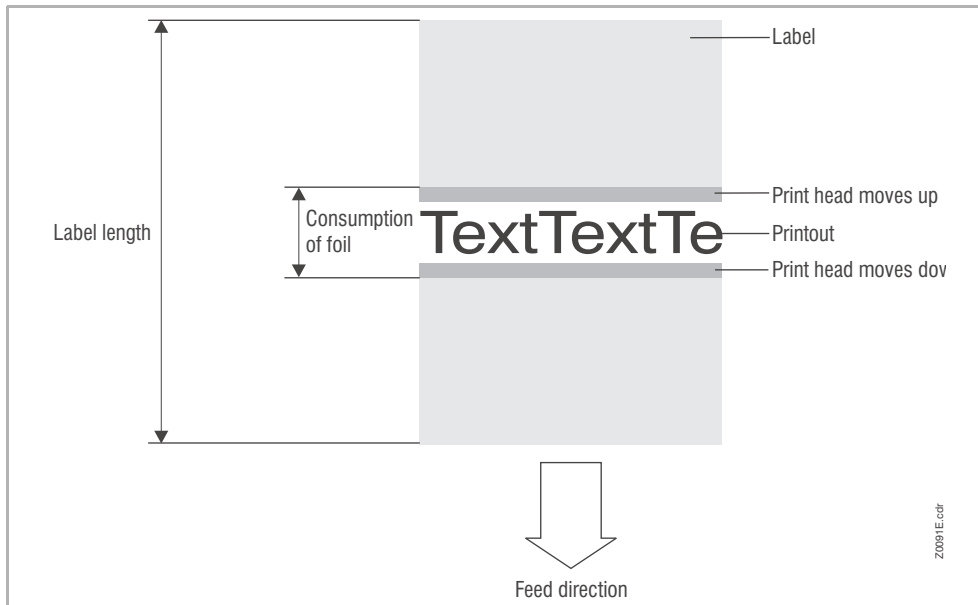

[17] Ribbon (Foil) consumption when printing labels with a small imprinting area and activated automatic ribbon economy. Ribbon consumption is slightly higher than the length of the imprinted area.

The effect of ribbon saving depends on the print speed. The reason for this is the up and down movement of the print head as well as the acceleration and slowing-down of the ribbon. Generally said: With a high print speed, less ribbon is saved as with a low print speed (Tab. 11).

Cutting or dispensing applications can additionally deteriorate the effect of ribbon saving.

**Activate** the automatic ribbon saving: See parameter SYSTEM PARAMETER >

Ribbon autoecon..

Setting the *minimum distance* between two print areas from which on ribbon saving should be activated: See parameter SYSTEM PARAMETER > Ribb. eco. limit.

▣ Mind the minimum length of unprinted area, see Tab. 11.

Print speed in mm/s (Inch/s)	Minimum length of unprinted area in mm	Consumed ribbon per sa- ving action in mm
51 (2)	3.7	1.2
76 (3)	4.6	1.9
102 (4)	5.9	3.1
127 (5)	7.4	4.4
152 (6)	8.9	5.9
178 (7)	11.1	7.6
203 (8)	14.1	9.5
229 (9)	17.6	11.3
254 (10)	21.3	13.6
279 (11)	25.3	15.9
305 (12)	30.0	18.5
330 (13)	34.5	21.2
356 (14)	39.9	24.2
381 (15)	45.6	27.3
406 (16)	51.3	30.5

[Tab. 11] The amount (length) of consumed ribbon per saving action (lifting and lowering of the print head) increases with the print speed.

CAUTION! - If huge ribbon rolls (run length of 1000m) are supposed to be used with activated ribbon economy function, there is a hazard of the ribbon tearing off.  
 → Consider the limitations according to Tab. 12 and Tab. 13!

Ribbon width	Ribbon type 2240-600-...			
	030	055	080	104
Max print speed with ribbon economy activated (inch/s)	12	12	12	12
Release the ribbon brake ... turns <sup>1</sup>	12	8	6	6

[Tab. 12] Limitations for ribbon type 2240-600-..., depending on the ribbon width.

1) Tighten the red hex nut at the unwind mandrel to the limit and then loosen it the indicated number of turns.

Ribbon width	Ribbon type 2240-1000-...			
	030	051	080	102
Max print speed with ribbon economy activated (inch/s)	12	10	9	6
Release the ribbon brake ... turns <sup>1</sup>	12	8	6	6

[Tab. 13] Limitations for ribbon type 2240-1000-..., depending on the ribbon width.

1) Tighten the red hex nut at the unwind mandrel to the limit and then loosen it the indicated number of turns.

For details on setting the ribbon brake refer to the user manual, chapter „Startup and operation“ > „Mechanical settings“ > **Setting the ribbon tension** □ on page 60.

## Mechanical features

### **Dispensing edge**

(DPM only) Adjustable for direct or indirect dispensing mode.

### **Label drive**

Forward and backward movement of labelling material for real 1:1 applications and full size print of labels

### **Label web tension**

Easy-to-adjust, patented reliable friction mechanism

### **Ribbon tension**

(DPM only) Adjustable by disc-brakes at the unwind- and rewind-mandrel.

### **Label sensor adjustments**

Mechanical via thumb wheel with position indicator, electrical setting via display function

## Ambient conditions

### **Installation location**

- Inside buildings
- Protected from wind and spray water
- Dry
- Not in areas with potentially explosive atmosphere

### **Operating temperature**

+5 bis +35°C

### **Storage temperature**

-20 to 70°C

### **Air humidity**

45 to 75% (non-condensing)

### **Protection class**

IP 21

### **Noise emissions**

< 70dB(A)

### **Sea level**

Operation to max. 2000 m above sea level

## Interfaces

Interface	Details
RS-232	Baud rate: 1200-115200, 8 bits
RS-232/422/485	Optional (I/O board <sup>1)</sup> ); Sub-D15, baud rate: 1200-115200, 8 bits
Ethernet	10/100 Base T with TCP/IP, LPD, RawIP printing, DHCP, HTTPD, FTPD, SNMP
USB (V1.1)	2x USB-A host port, 1x USB-B device port, transfer rate 12 Mb/s.
Centronics	Optional (Centronics board <sup>1)</sup> ); Bidirectional mode (nibble mode) corresponding to IEEE 1284 B
Signal Interface USI	(USI board <sup>2)</sup> ): General control signals, signal voltage: 24 V or 5 V (different boards)
Connection for external operation panel	Optional (internal wiring + connector); RS485, Mini-DIN-6 connector
APSF-sensor (rotary encoder)	Optional (internal wiring + connector); Single-phase/two-phase, PNP/P-P, 24 V, max. 20 kHz

[Tab. 14] Data interfaces on the ALX92x.

- 1) I/O board and Centronics board are mutually exclusive. Only one of the two additional boards can be installed in the same machine.
- 2) USI board and AI board are mutually exclusive. Only one of the two additional boards can be installed in the same machine.

## Electronic equipment

Feature	Details
CPU	32 bit MIPS
RAM	64 MB
ROM	4 MB
Memory card slots	SD/MMC CompactFlash
Control panel	5 keys; LCD graphical display with 128x32 pixels; typically two lines are displayed with 16 characters each

[Tab. 15] Electronic equipment for ALX92x.

## Certificates and Markings

CE, TÜV-Mark, <sub>C</sub>TÜV<sub>US</sub>-Mark, FCC, EAC, CCC

The regulation EN 55022 demands for class A devices the following text to be printed in the manual:

„WARNING: This is a class A product. In a domestic environment this product may cause radio interference in which case the user may be required to take adequate measures.“



The FCC regulation demands the following information text for class A devices:

„NOTE: This equipment has been tested and found to comply with the limits for a Class A digital device, pursuant to Part 15 of the FCC Rules. These limits are designed to provide reasonable protection against harmful interference when the equipment is operated in a commercial environment. This equipment generates, uses and can radiate radio frequency energy and, if not installed and used in accordance with the instruction manual, may cause harmful interference to radio communications. Operation of this equipment in a residential area is likely to cause harmful interference in which case the user will be required to correct the interference at his own expense.“

IC (Industry Canada) requires the following wording for Class A devices:

„CANADIAN D.O.C. WARNING This digital apparatus does not exceed the Class A limits for radio noise emissions from digital apparatus set out in the Radio Interference Regulations of the Canadian Department of Communications.“

## OPTIONS

To find the article numbers of the options, refer to the sales documents - ask your NOVEXX Solutions re-seller.

### External control panel

In addition to the permanently installed control panel, an external control panel can be connected.

An external control panel is advantageous if the installed control panel is difficult to access due to the installation position of the machine.

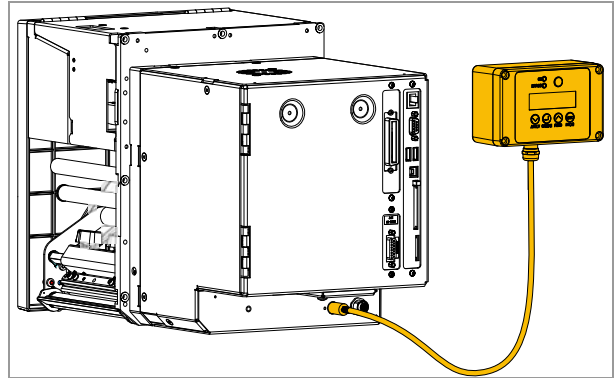

[18] External control panel

### Connector for rotary encoder for APSF (DPM)

Connector for a rotary encoder. Enables the automatic adaption of the print/dispense speed to the product speed.

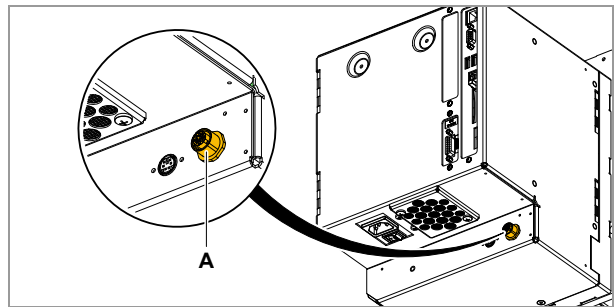

[19] Connector (A) for a rotary encoder.

### Centronics interface

Accessory board [20A] providing a Centronics interface.

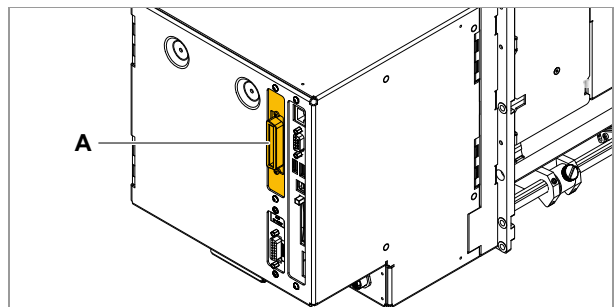

[20] Centronics interface (A) at a DPM RH.

### RS232/422/485 interface

Accessory board [21A] providing an additional serial interface (RS232 or RS485 or RS422).

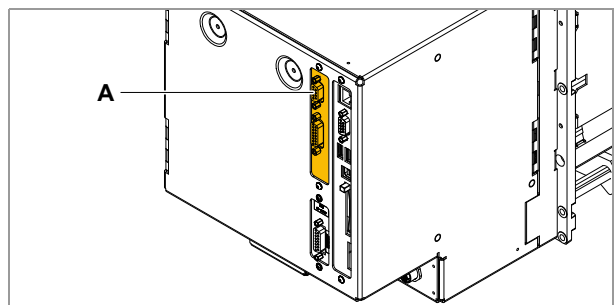

[21] Additional serial interface (A) at an ALX 92x RH.

### Ribbon core adapters

Push-on core adapters; those are required for use of 1000 m ribbon rolls with 1,5" core diameter.

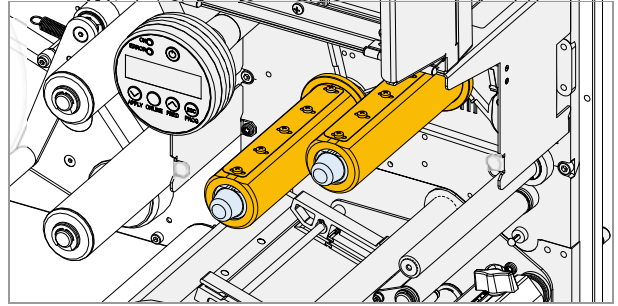

[22] Ribbon core adapters.

### Pressure roller (DPM)

The pressure roller attaches the labels onto the product. It is required in „direct dispensing“ mode.

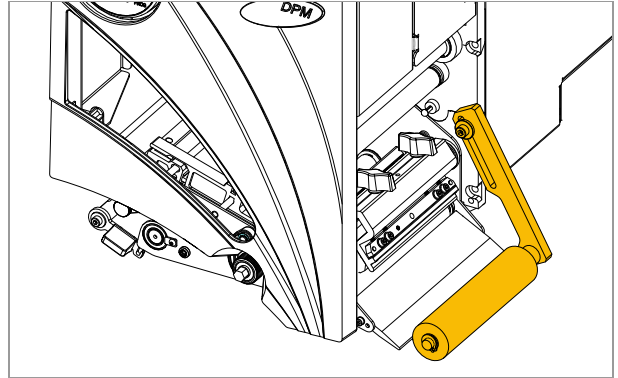

[23] Pressure roller at an ALX 92x.

### Long dispensing edge (DPM)

Recommended dispensing edge for direct dispensing.

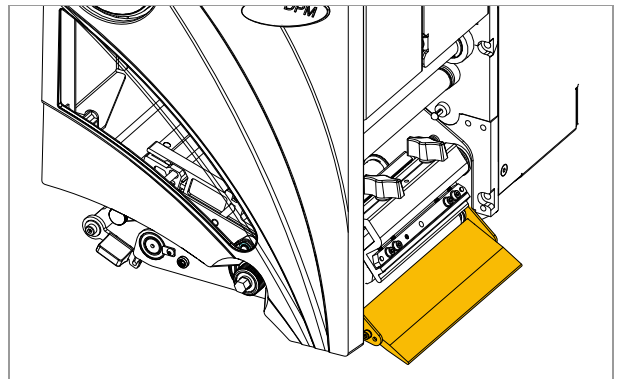

[24] Long dispensing edge.

### Deflection roller for vertical material feeding

This deflection roller is required, if the label material is fed in a very steep angle from top.

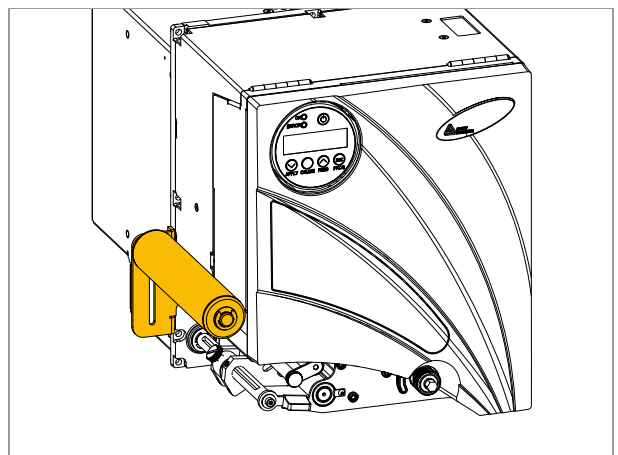

[25] Deflection roller for vertical material feeding.

## OPERATING MODES

### Overview

- Online mode
  - Print jobs are received and processed immediately
  - Active operating mode after switching on
  - Print contrast setting
- Offline mode
  - Print jobs are received but are not processed
  - Access to the parameter menu
- Standalone mode
  - Print mode without data line
  - Print job on memory card

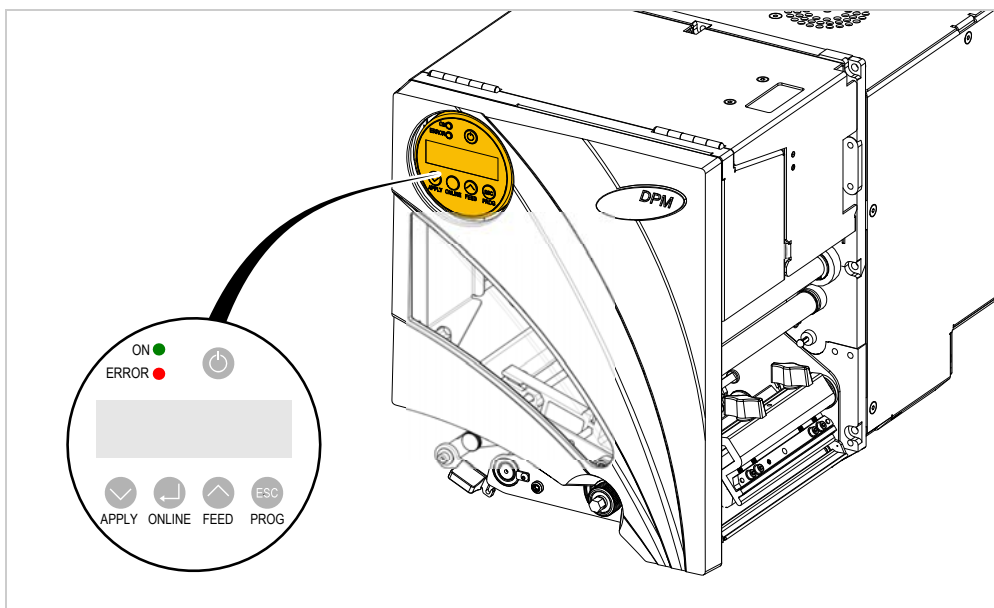

[26] Control panel at the DPM.

## Online mode

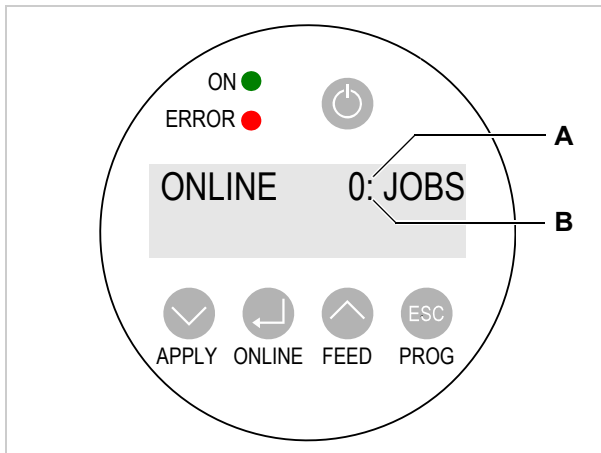

[27] Control panel of the DPM in online mode.

- A Interpreter activity
- B Data transfer

### Activate online mode

Activate from offline mode:

→ Press the ONLINE key.

Screen:

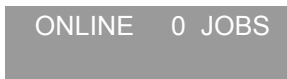

(There are no pending print jobs for processing).

### Data transfer and interpreter activity



Screen showing *data transfer*:

A *data transfer* to the printer that is currently in progress is indicated in the display by a dot on the right below the number of jobs loaded [27B].

Screen showing *interpreter activity*:

An additional dot above the first one at the vertical midpoint of the line [27A] indicates activity of the interpreter:

- *No dot*: No data to interpret.
- *Dot*: The interpreter is working (data still present in the spooler)
- *Flashing dot*: The interpreter is waiting for additional data to be able to complete the command (no data in the spooler).

**Screen showing the progress of printing**

Screen during printing:

- Number of received print jobs (13)
- Number of remaining labels to be printed in the current job (25)

```
ONLINE 13 JOBS
Restcount: 25
```

```
ONLINE 13 JOBS
Restcount: Endless
```

▣ If a printer job has been specified as *endless*, i.e., there is no limit to the number of labels to be printed, the remainder for this job will also be endless.

**Stop/continue print process**

Screen during printing:

```
ONLINE X JOBS
Restcount: yy
```

To stop the print process:

→ Press the ONLINE key.

The label currently being printed is completed. Screen:

```
ONLINE X JOBS
Stopped : yya
```

a) "Stopped: yy" alternates with "Press Feed".

To continue the print process:

→ Press the FEED key.

```
ONLINE X JOBS
Restcount: yy
```

**Adjust the print contrast**

**CAUTION!**

The print contrast parameter directly affects the service life of the printhead. The higher the setting of the print contrast, the shorter the service life of the printhead. This applies especially to settings over 100%.

→ Always select the lowest setting that will still produce acceptable printing results.

```
ONLINE X JOBS
Restcount: yy
```

→ Press the PROG key.

```
Print contrast
xxx%
```

→ Set the print contrast with the FEED / APPLY keys.

→ Accept the setting with the ONLINE key.

## Offline mode

### Activate offline mode

Normally <sup>1</sup> activated automatically after switching on.

To activate from online mode (when the print job is stopped):

→ Press the ONLINE key.

```
OFFLINE  0 JOBS
```

(There are no pending print jobs for processing).

```
OFFLINE  X JOBS  
Stopped : yy
```

(The operator has switched from stopped online mode to offline mode)

### Material feed forwards/backwards

Material feed up to the start of the next label:

→ Press the FEED key.

```
OFFLINE  X JOBS  
feeding...
```

Slow material and ribbon feed:

→ Press and hold ONLINE + FEED keys.

```
OFFLINE  X JOBS  
feeding...
```

Slow material transport backwards:

→ Press and hold ONLINE + APPLY keys.

```
OFFLINE  X JOBS  
feeding...
```

---

1) Requirement: factory setting or SYSTEM PARAMETERS > Turn-on mode = "Offline"

### Opening the parameter menu

In the parameter menu the user has access to a number of menus in which various parameters can be called in a defined order.

The dispenser can be set so that some menus and/or parameters are not visible.

Figure [28] shows the key functions for switching between different menus and for exiting the parameter menu.

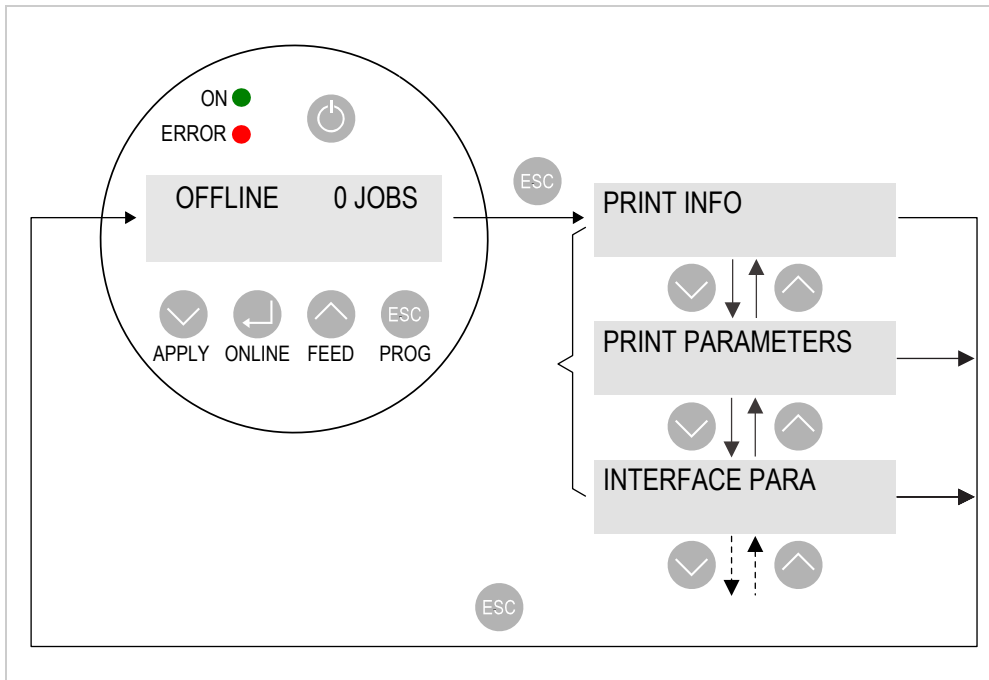

[28] Menu selection and key functions in the printer parameter menu.



**Setting parameters**

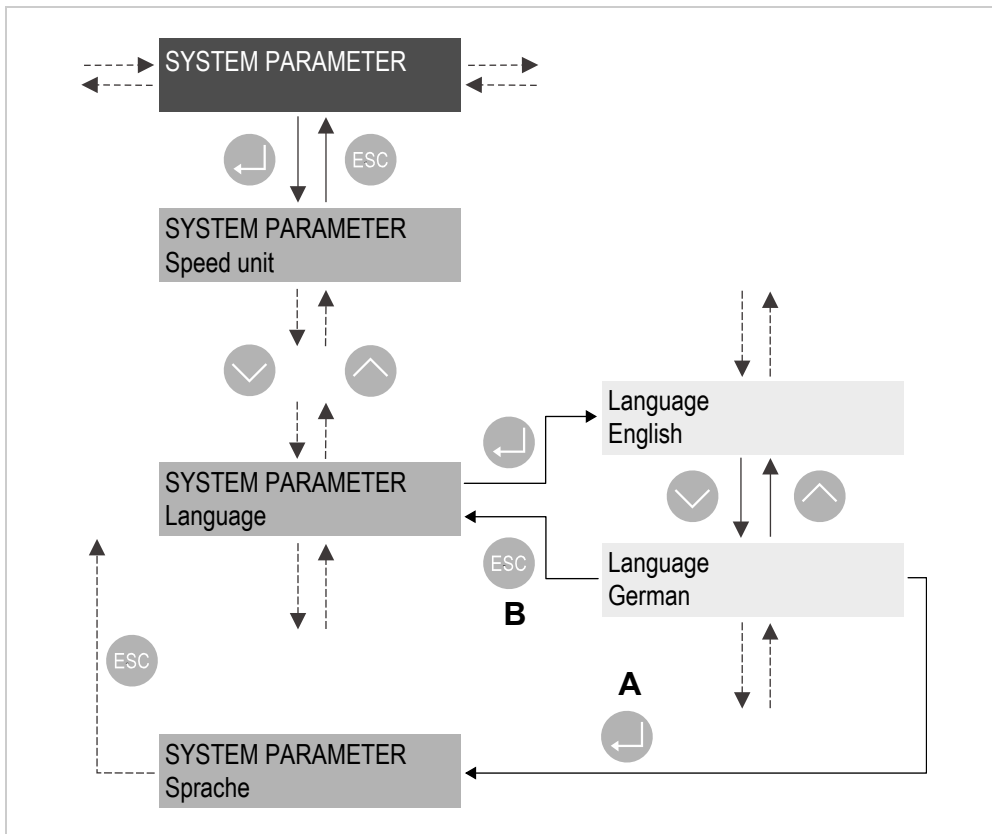

[29] Key function when setting the SYSTEM PARAMETER > Language parameter.  
**A** Key for "Accept change"  
**B** Key for "Reject change"

Each menu contains parameters that can be used to make settings on the machine control unit. Fig. [29] shows the SYSTEM PARAMETER > Language parameter as an example of the key functions for changing settings.

**Dot check for printhead**

The printhead dot check is used to detect faulty dots on the printhead.

**CAUTION!**  
 Danger of damaging the printhead.  
 → Do not switch off the machine under any circumstances during the dot check!

→ Press the APPLY + FEED keys.

OFFLINE X JOBS  
 Head dot test

## Standalone mode

In standalone mode, print jobs are not transferred via data cable but are instead stored on a memory card. You can access them there from the printer control panel or using a connected keyboard.

### Activate standalone mode

1. Switch off the machine.
2. Save relevant print jobs in the \Formats directory on the memory card.
  - ▮ Files with print jobs must have the ending \*.for.
3. Insert the memory card in the printer's card slot.
4. Switch on the machine.
  - Initial operating mode: online or offline.
5. Press the ONLINE + PROG keys.

Screen:

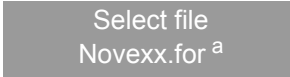

Select file  
Novexx.for<sup>a</sup>

- a) Filename of the print job. If there are several print jobs: filename of the first print job in alphabetical order.

Screen if no file was found:

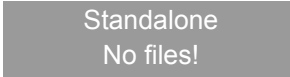

Standalone  
No files!

### Starting a print job

1. Activate standalone mode as described above.
2. If there are several print jobs: Press the FEED / APPLY keys until the required print job appears.
3. Press the ONLINE key to confirm the selection.

Screen:

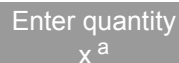

Enter quantity  
x<sup>a</sup>

- a) Assignment for quantity (in this case x) is included in the print job.

▮ Depending on the print job, the user may be prompted for additional entries.

4. Press the ONLINE key to confirm the number or the Esc key to delete the number.
5. Proceed in the following manner for each required digit:
  - Press the FEED / APPLY keys to select a number from 0 to 9.
  - Press the ONLINE key to move to the next digit.
6. Press the ONLINE key twice to confirm the selection.
  - The print job is now processed.
7. You can also optionally press the ONLINE + PROG keys to switch to online mode.

## PARAMETER MENU

### Overview of parameter menu

PRINT INFO	PRINT PARAMETERS	INTERFACE PARA	SYSTEM PARAMETER	(DP INTERFACE)
...	Print speed	...	...	...
	Feed speed		Label sens. type	
	Materialtype		...	
	Materiallength		Ribbon autoecon.	
	Materialwidth		Ribb. eco. limit	
	Print direction		...	
	...		Print contrast	
	X - Printadjust		...	
	Y - Printadjust			
	...			

[Tab. 16] Printer parameter menu part 1

(MLI PARAMETERS)	(I/O BOARD)	SPECIAL FUNCTION	SERVICE FUNCTIONS	SERVICE DATA
...	...	...	...	...
		Delete Job	Head dot test	
		Delete Spooler	...	
		...	Print test	
		Store Parameters		
		Store diagnosis		
		...		

[Tab. 17] Printer parameter menu part 2

- Menu title in brackets: Configuration of the printer determines whether the menu is visible.
- „...“: Place holders for one or more parameters which are not described below.



Settings to parameters that are not described here require specialist knowledge and must only be made by qualified service personnel. These parameters are described in the Assembly/Service manual.

### Information about the parameter description

- The setting range or the individual settings of a parameter are shown in square brackets.
- For parameters with individual setting values, the preset value is shown in italic type.

## PRINT PARAMETERS menu

### Print speed

Print speed

The print speed (material feed) can be adapted to the combination of ribbon and material in use to optimise the contrast intensity and the degree of blackening of the print image.

Setting range: [2...16] inch/s; presetting: 8 inch/s

### Feed speed

Feed speed

The feed speed can be increased in areas with no print. This reduces the overall print time, especially for long labels with very little printed surface.

▣▣▣▣ When the print speed is changed, the feed speed is set equal to the print speed. If a different feed speed is preferred, it must be set again.

Setting range: [2...12] inch/s; presetting: 8 inch/s

### Materialtype

Definition of the label material in use.

Settings: [Endless, *Punched*]

- Endless: The label material has no punches or reflex markings. The start of the label is calculated by the set label length (PRINT PARAMETERS > Materiallength).
- Punched: The individual labels in the label material that is used have punches or reflex markings that can be detected by the label sensor.

### Materiallength

Label length, measured from the front (beginning) of a label to the front of the next label.

Setting range: [5...max. length <sup>1</sup>] mm; presetting: 100 mm

### Materialwidth

Width of the label belt (including backing paper in the case of self-adhesive material).

Setting range: [Min. width <sup>2</sup>...Max. width <sup>3</sup>] mm; presetting: 100 mm

---

1) "Max length": depends on the printhead width and memory configuration.

2) "Min. width": depends on the type of printer

3) "Max. width": depends on the printhead width and memory configuration of the printer

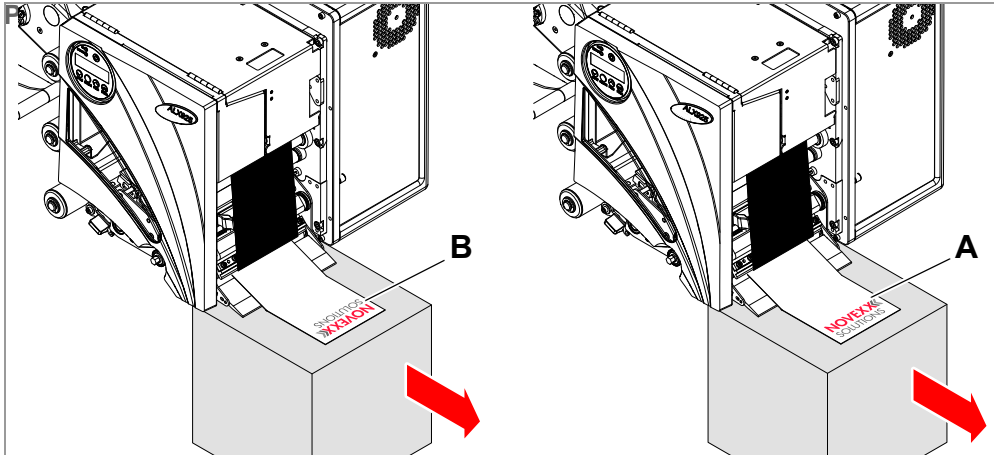

[30] Alignment of the print image "Foot first" (A) or "Head first" (B).

Settings: [„Foot first“, „Head first“]

- "Foot first": Alignment of the print image as shown in [30A].
- "Head first": Alignment of the print image as shown in [30B]. Note the following:
  - ▮ Define the "true" label length (without label gaps) in parameter PRINT PARAMETERS > Material length. If the label gap is longer than 5 mm parameter SYSTEM PARAMETER > Miss. label tol. must also be set to a value greater than zero.
  - ▮ The distance between the material zero line and the first printable dot is 1 mm. To maintain this distance in head first mode, calculate the material using the following formula:

$$b_{Mat} = b_{Tr} - 2mm, \text{ where}$$

$b_{Mat}$ : Material width

$b_{Tr}$ : Carrier material width

### X - Printadjust

The zero point of the mask is shifted in relation to the edge of the label on the X-axis, i.e. perpendicular to the material.

- ▮ If the setting is changed while a print job is stopped, the printer recalculates the format with the modified values.

Setting range: [-15.0...+15.0] mm; presetting: 0 mm

- Maximum adjust (offset) away from the edge of the label: +5.0 mm
- No offset: 0.0 mm
- Maximum offset toward the edge of the label: -5.0 mm

### Y - Printadjust

The zero point of the mask is shifted in relation to the punch position on the Y-axis, i.e. in the direction of feed.

- ▮ If the setting is changed while a print job is stopped, the printer recalculates the format with the modified values.

Setting range: [-15.0...+15.0] mm; presetting: 0 mm

- Maximum offset in feed direction: +5.0 mm
- No offset: 0.0 mm
- Maximum offset opposite to feed direction: -5.0 mm

## SYSTEM PARAMETER menu

### Label sens. type

Sensor type

Select the sensor type or the type of mark for beginning of the label (reflex marking or punch).

Settings: ["Reflex", "Punched"]

- Reflex: Reflex sensor (detects reflex markings)
- Punched: Transmission sensor (detects reflex punches)

### Ribbon autoecon.

Ribbon saving (ribbon autoeconomisation)

Ribbon saving can be used to interrupt ribbon feed through areas of the label that are not printed. This saves ribbon, especially for long labels with very little printed surface.

Compared to the „normal“ ribbon saving function can the label throuput be considerably increased by setting the „turbo“ ribbonsaving mode (On Turbo). This mode allows setting the feed speed in print free areas independent from the print speed via PRINT PARAMETERS > Feed speed.

Settings: ["Thermal/headlift" "Thermal printing", "On", "Off", „On Turbo“]

- "Thermal/headlift": Thermal direct printing with automatic head lifting over unprinted areas (protects the printhead)
- "Thermal printing". Thermal direct printing (ribbon end sensor shut off)
- "On": Thermal transfer printing with ribbon saving
- "Off": Thermal transfer printing without ribbon saving
- „On Turbo“: Thermal transfer printing with „turbo“ ribbon saving

### Ribb. eco. limit

The ribbon economisation limit corresponds to the length of the no-print zone on the label at the point where ribbon autoeconomisation will be activated.

■► Do not activate ribbon autoeconomisation for unprinted areas unless they are more than about 10 mm in length.

Setting range: [2.0...100.0] mm; presetting: 10.0 mm

### Print contrast

The setting for print contrast, i.e. the degree of blackening in the printout.

#### CAUTION!

The Print contrast parameter directly affects the service life of the printhead. In general, the higher the setting of the Print contrast, the shorter the service life of the printhead. This applies especially to settings over 100%. Therefore note the following recommendation:

→ Always select the lowest setting that will still produce acceptable printing results.

Setting range: [1...110%]; presetting: 60%

## SPECIAL FUNCTION menu

### Delete Job

Deletes the active print job.

When the online key is pressed, the printer interrupts processing of the active print job.

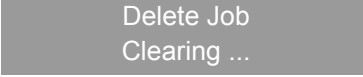

### Delete Spooler

Deletes the print job wait queue (spooler).

When the online key is pressed, all print jobs in the print spooler are deleted.

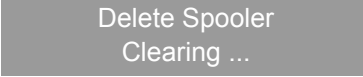

### Store Parameters

Save settings in the parameter menu.

Parameter settings are saved in a text file on memory card (directory FORMATS\). Also takes into consideration parameters belonging to uninstalled options.

Settings: ["Without adj. par", "With adjust para"]

- "Without adj. par": Parameters containing device-specific settings are *not* saved.  
*Application:* Transfer of settings to other devices (device-specific settings such as heat resistance or sensor settings should not be overwritten).

Pre-set filename: SETUP.FOR

- With adjust para

Parameters containing device-specific settings are saved *as well*. The relevant parameter names are marked in the text file with a \*.

*Application:* Service

Pre-set filename: SETUPALL.FOR

### Store diagnosis

Saves diagnostic data to memory card.

Pre-set filename: Diagnose ALX 924 RH A662105104002453.log where...

- "ALX 924 RH": Printer type
- "A662105104002453": Serial number of the CPU board; corresponds to the entry in SERVICE DATA >CPU BOARD DATA > Serial number

## SERVICE FUNCTIONS menu

### Head dot test

Checks the printhead for faulty dots. The check ends with a status report [31] containing a list of faulty dots. This printout is generated even if no faulty dots were found.

**CAUTION!**

Danger of damage to the printhead.

→ Do not switch off the printer under any circumstances during the dot check! Failure to observe this instruction may cause dots to be destroyed.

The following screen appears during the check:

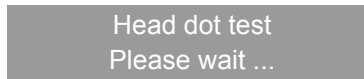

▣▣▣▣ Required label material: 200 x 100 mm (length x width).

<b>Head Dot Test Status</b>									
<b>Head data</b>									
<b>Head resistance</b>	: 1364 Ohm								
<b>Print width</b>	: 128.0 mm								
<b>Print resolution</b>	: 12.0 Dots/1 µm								
<b>Number of dots</b>	: 1536 Dots								
<b>25 defective print dots</b>									
1,	417,	418,	419,	557,	700,	761,	770,	771,	
772,	773,	774,	775,	776,	777,	778,	779,	780,	
781,	782,	783,	784,	833,	834,	835,			

[31] Status report after the dot check has been successfully completed. Top section: Technical data for the printhead; bottom section: faulty dots.

▣▣▣▣ The dot check can also be started in offline mode by pressing the APPLY + FEED keys. There is no status report in this case, however.

### Print test

A general print test; prints the set printer type and the number of the firmware version in different fonts arranged by line with material settings such as material type, length and width also taken into consideration.

→ To exit the print test press the ONLINE key.



# Startup and Operation

## ELECTRICAL CONNECTIONS



### WARNING!

This unit operates at mains voltage! Contacting electrically live components can cause lethal electrical shocks and burns.

- Make sure that the device is switched off before connecting the power cable.
- Only operate the unit at the mains voltage given on the type plate.
- Only connect the device to a grounded power socket fitted to authorised standards.
- The power cable should be run to the device so that a) nobody will trip on it, and that b) the power plug can easily be pulled out if necessary.
- The maximum permitted length of the mains power connecting line is 3 m.
- To disconnect the device completely, the power cable has to be pulled off.

### Connecting to the mains power supply

1. Ensure that the machine is switched off (mains power switch [32A] in position "O").
2. Connect the machine to a mains power socket [32C] using the provided power cable [32B].

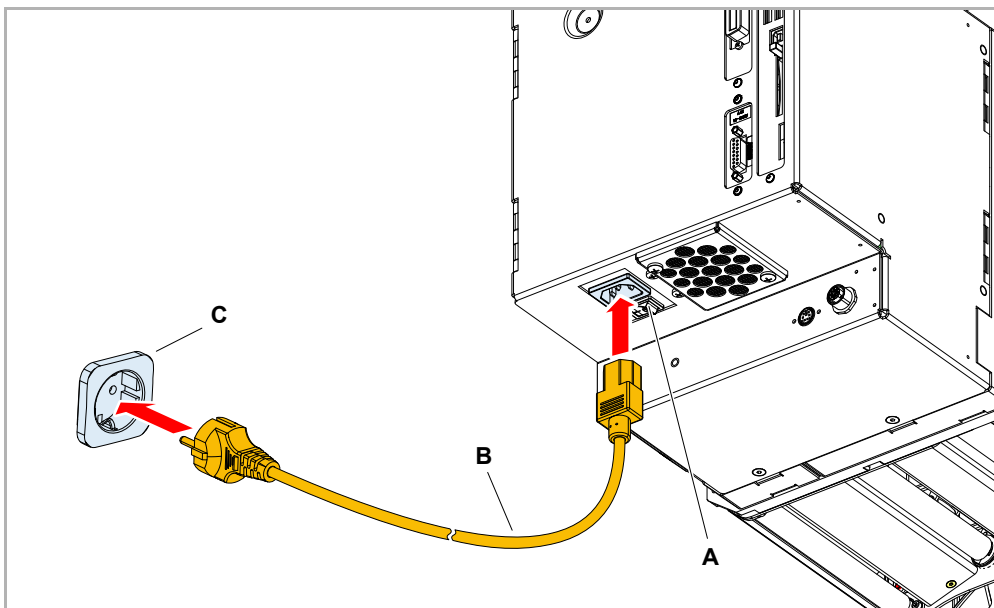

[32] Connecting the DPM/PEM. to a mains power socket.

## Connecting to a data host

According to the factory settings, the DPM/PEM is set for data transfer via USB interface. Print data can also be transferred via a serial interface, Ethernet or an optional Centronics interface.

Alternatively to transmitting via data line, the printjobs can be stored on a memory card and be started from there, see **Transferring a print job** on page 65.

The interface type is selected with the following parameter: INTERFACE PARA >EASYPLUGINTERPR > Interface

You might have to set other parameters as well, depending on the interface chosen:

- Settings for the Centronics interface:  
INTERFACE PARA > Centronics
- Settings for the serial interface (Com 1 or Com 3<sup>1)</sup>: INTERFACE PARA >>COM1 PORT or INTERFACE PARA >COM3 PORT.
- Settings for the Ethernet interface: INTERFACE PARA >NETWORK PARAM.

For details about *data transmission* read the user manual, chapter „Startup and operation“ > „Printing“ > **Transferring a print job** on page 65.



Ordering numbers for power cables or *data cables* can be found in the Service Manual, topic section „Spare Parts“, chapter „Accessories“.

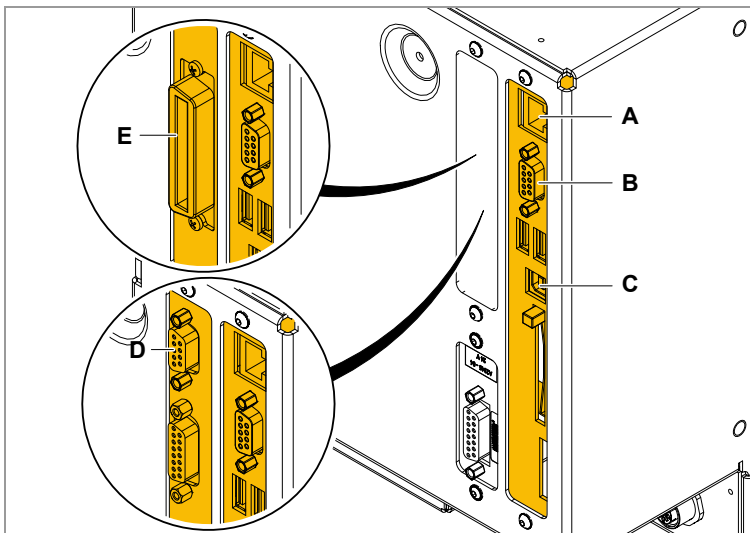

[33] Data interfaces at the DPM/PEM.

- A Ethernet
- B RS 232
- C USB
- D Centronics (optional)
- E RS 232/422/485 (optional)

1) If the optional 2nd serial interface is installed.

## Connecting sensors



**WARNING!**

This unit operates at mains voltage! Contacting electrically live components can cause lethal electrical shocks and burns.

→ The machine must only be connected with other machines if they meet the requirements of a SELV circuit (Safety Extra-Low Voltage circuit) in accordance with EN 60950.

→ Before switching on the machine, check to ensure all required sensors are securely connected.

### Minimum required sensors

Product sensor

- Assembly location: assembly line
- Connection: Sub-D connector at USI

### Optional additional sensors

Sensors for OD<sup>1</sup> detection:

- Assembly location: assembly line
- Connection: Sub-D connector at AI or USI (both optional boards)



The sensor cables must be produced and connected by an authorised specialist who is aware of the risks involved.



More extensive information about suitable sensor types, pin assignment, etc. may be found in the Assembly/Service manual.

---

1) OD = Outer Diameter (of the material roll)

## INSERTING LABEL MATERIAL



### WARNING!

Danger of injury due to moving and rapidly rotating parts!

- When working on the device, do not wear loose jewellery, long sleeves, long hair, and similar
- Before inserting the label roll ensure that the machine is in offline mode.
- Close the devices cover before printing

Danger of injury caused by falling label roll.

- Wear safety shoes.

During operation, the printhead can become hot.

- Be careful when touching the printhead!

Die Abwicklung und Zuführung des Etikettenmaterials und die Aufwicklung des Trägermaterials am DPM hängen von der jeweiligen Systemumgebung ab und können deshalb nicht in diesem Handbuch beschrieben werden.

### Threading-in the label web (DPM)

1. Open the front cover [34].
  - ▮ Hold the cover on the bottom right [34A].

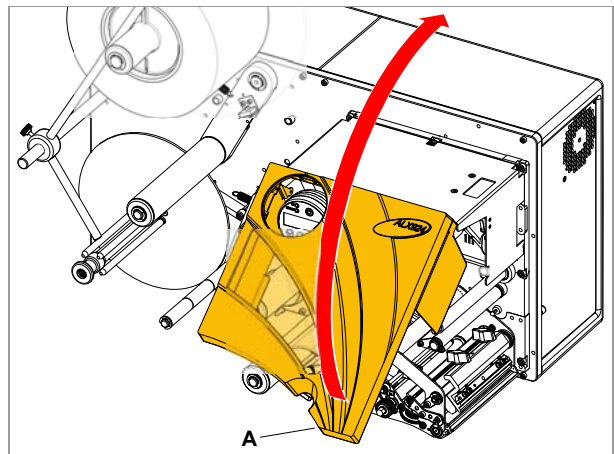

[34] Open the cover.

2. Adjust the material guide to the width of the label web. To do this, release the thumb screw [35A] on the outer material guide [35B], push the material guide up to the edge of the label material and screw in the thumb screw again until it is tight.
  - ▮ The label material should move easily between the guides.
3. Push the label material through the material guide and up under the pressure rollers.
4. Detach the pressure roller. To do this, press the green lever [35C]. Hold the lever pressed and push approx. 50 cm of label material through under pressure rollers and printhead.

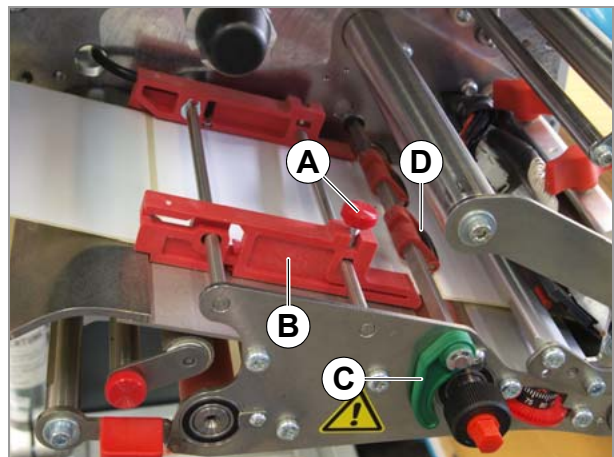

[35] Adjusting the material guide.

5. Peel off the labels between the printhead and the end of the label web [36].
6. Press down the green lever and position the contact rollers [35D] on the label web while doing so.  
▮▮▮▮▮ The contact rollers should press down the material evenly.



[36] Peel the labels off on a length of 50 cm.

7. Open the pressure roller lever [37A] by pressing it downwards
8. Pull the backing paper backwards underneath the printing module and insert it as illustrated [37].  
Continued overleaf.

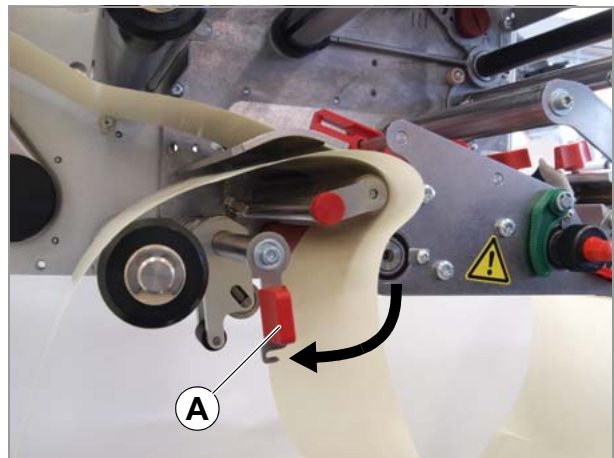

[37] Inserting the backing paper at the feed roller.

9. (DPM 4 only) Loosen the thumb screw [38A] at the spring-suspended block. Position the spring-suspended block [38B] in a way that the contact rolls press evenly on the backing paper web. Retighten the thumb screw.

(DPM 5/6 only) Loosen the two thumb screws [39A] at the spring-suspended blocks. Position the spring-suspended blocks [39B] in a way that the contact rolls press symmetrically on the backing paper. Retighten the thumb screws.

10. Tighten the backing paper backwards and close the lever.

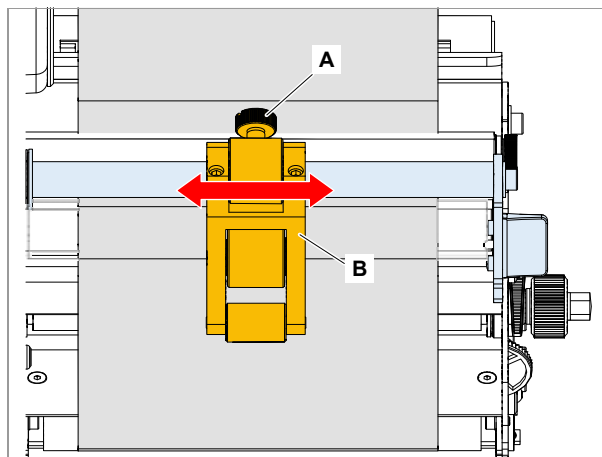

[38] Pressure roller at the DPM 4 (some parts hidden for better visibility).

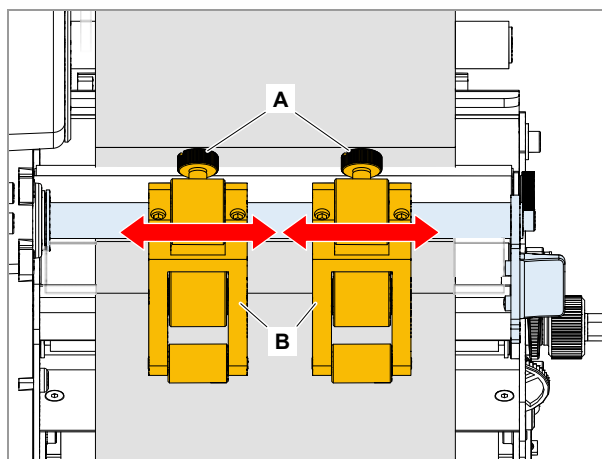

[39] Pressure rollers at the DPM 5/6 (some parts hidden for better visibility).

## Threading-in the label web (PEM)

1. Open the printer cover [34].  
 ▮▮▮ Hold the cover on the bottom right [34A].

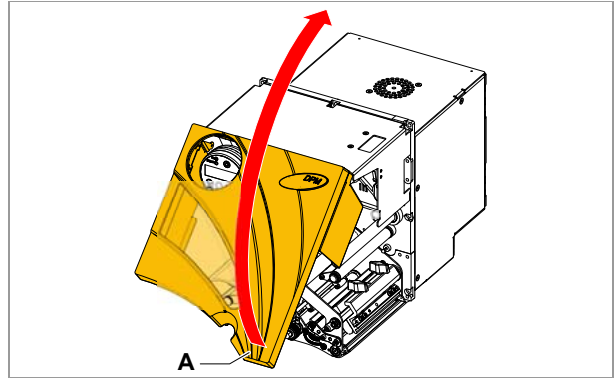

[40] Open the front cover.

2. Adjust the material guide to the width of the label web. To do this, release the thumb screw [41A] on the outer material guide [41B], push the material guide up to the edge of the label material and screw in the thumb screw again until it is tight.  
 ▮▮▮ The label material should move easily between the guides.
3. Push the label material through the material guide and up under the pressure roller.
4. Detach the pressure roller. To do this, rotate the green lever [41C] in the direction of the arrow.
5. Push the material end under the printhead.
6. 2,5 Unroll the 2.5-m label web and remove the labels from it.
7. Close the green lever [42].

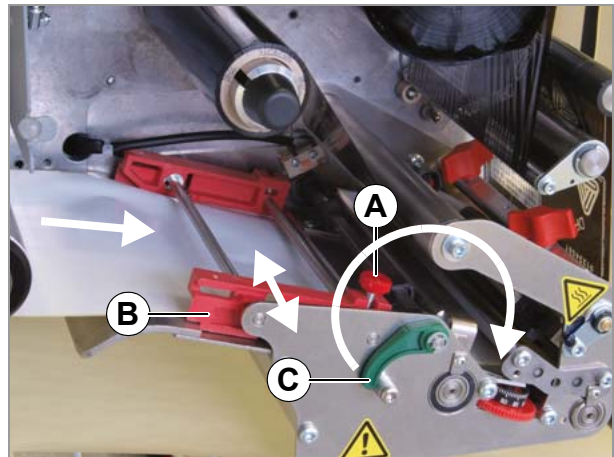

[41] Adjust the material guide (B) for the width of the material.

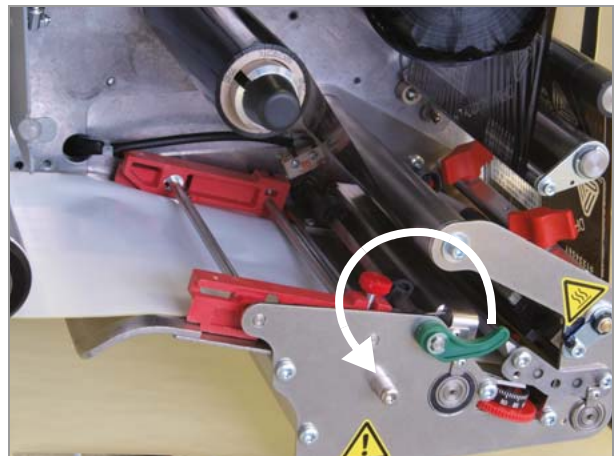

[42] Shut the lever for the pressure roller.



## INSERTING/REPLACING RIBBON



**WARNING!**

Rotating parts can entrap objects and body parts and draw them in!

- Never wear loose long hair, loose jewellery, long sleeves or similar items when working with the machine.
- Always close the printer cover before printing.

The printhead can become hot during operation!

- Be careful whenever touching the printer.

**CAUTION!**

If the diameter of the wound ribbon becomes too large, this will impair the printer operation.

- Always remove the used ribbon before inserting a new ribbon roll.

### Inserting ribbon

1. Open the cover.
2. If necessary remove used ribbon.
3. Place a new ribbon roll on the ribbon unwinding mandrel [45A]. Insert an empty take-up roll onto the ribbon rewinding mandrel [45B].
4. Insert the end of the ribbon below the ribbon deflector [45C] and thread through to side of printhead [45D].
5. Pull the ribbon below the printhead from the side. Next, unwind some ribbon and smoothen it out.
6. Pull the ribbon upwards and, as shown [43], pass it around the ribbon roller [45E], ribbon deflection roller and strain relief [45F].
7. Fasten the end of the ribbon to the take-up roll mandrel [45].

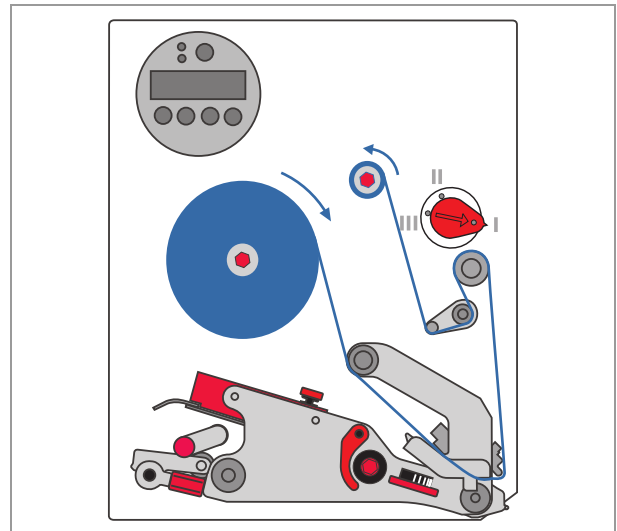

[43] Threading diagram for ribbon.

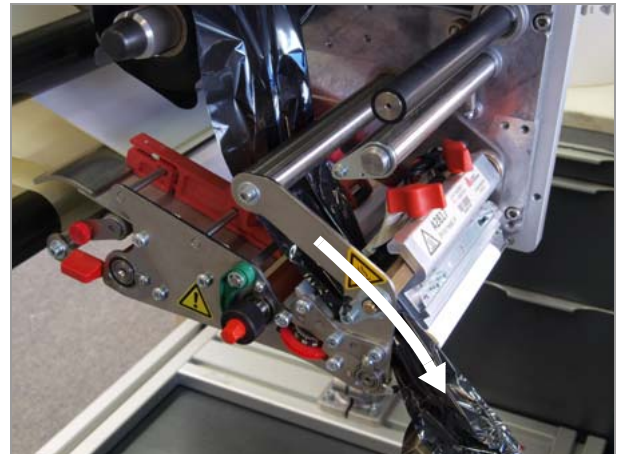

[44] Threading the ribbon end to the side of the printhead.

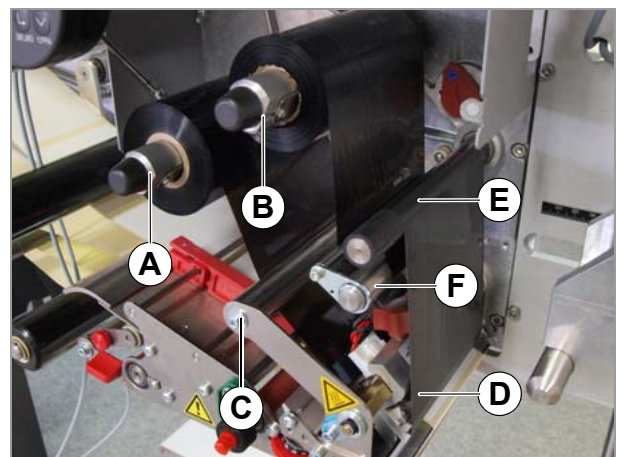

[45] DPM with ribbon inserted.

- A** Ribbon unwinding mandrel
- B** Ribbon winding mandrel
- C** Deflector
- D** Printhead
- E** Ribbon roller
- F** Strain relief



## Changing ribbon

### With roll diameter monitoring

We recommend switching on roll diameter monitoring, see section **Ribbon reserve**  on page 64.

As soon as the critical diameter is reached, the message appears:

```
FOILØ X JOBS
```

Follow these steps:

1. Open the front cover.  
The printer prints the current label completely and then stops.

```
PrintStatus: 5103  
Cover open
```

2. Change the ribbon roll.
3. Close the front cover.  
The status message is confirmed automatically.
4. Press the FEED key.  
The current print job continues.

### Without roll diameter monitoring

As soon as the ribbon roll is used up, the following message appears:

```
PrintStatus: 5008  
Foil end
```

The printer stops immediately, without printing the current label.

1. Open the front cover.  

```
Print status: 5103  
Cover open
```
2. Change the ribbon roll.
3. Close the front cover.  
The status message is confirmed automatically.
4. Press the ONLINE key to confirm the ribbon end message.
5. Press the FEED key.
6. Remove the label that was not completely printed.  
The last (incomplete) label to be printed will be printed again. Then printing continues with the current print job.

## MECHANICAL SETTINGS

The pictures show a DPM. The settings at the PEM are the same.

### Position the label sensor

The printer is equipped with a transmission sensor.

By moving the red thumb wheel [46B], you can adjust the sensor within a range of 80 mm DPM/PEM 4/5) or 100 mm (DPM/PEM 6) perpendicular to the material. The dial shows the currently set value [46A].

Reading the value:

$$\text{Set value} = \text{punch position} - 2 \text{ mm}$$

...where:

- Punch position:  
Distance of punch from (inner) edge of material [47].
- Set value:  
Dial value to be set by turning the red wheel.

Example: Punch centre = 11 mm from left edge, subtract 2 mm leaving 9 mm as the setting.

→ To make the setting, adjust the wheel [46B] until the required setting faces the marking [46C].

▣ Round labels: To ensure that the start of the label is correctly detected here, it may be necessary to define a preset value for the punch offset. This can be set manually on the printer (parameter PRINT PARAMETERS > X - Printadjust) or using an appropriate Easy-Plug command.

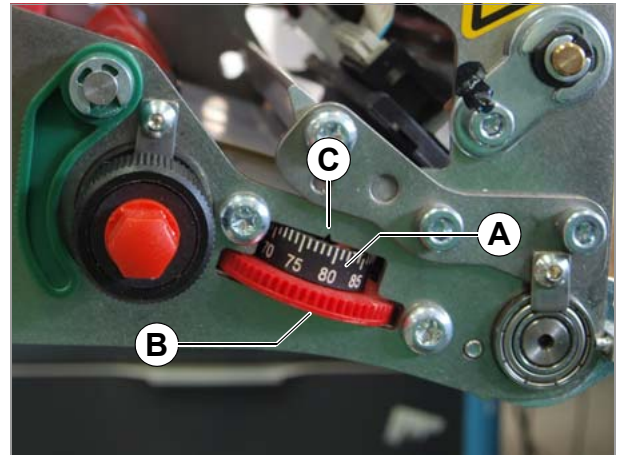

[46] Thumb wheel (B) of the label sensor.

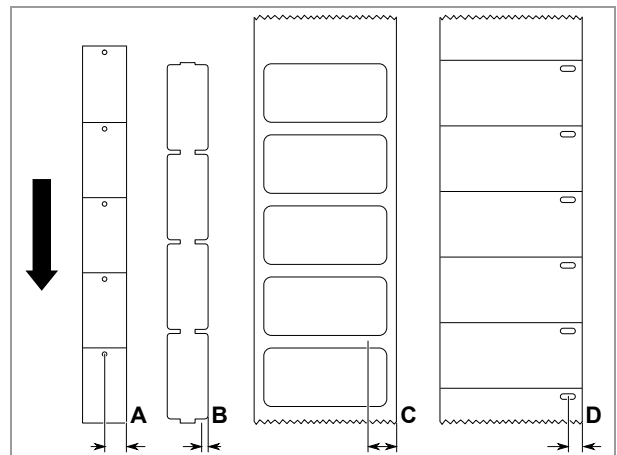

[47] Measuring the punch position (RH machine). C: arbitrary sensor position with centre die cut label material.

## Setting the ribbon tension

For optimum printing results, the ribbon must run without creases. This can be achieved by correctly setting the torque on the rewinding mandrel and the braking torque on the unwinding mandrel.

The factory settings cover a wide range of different ribbon widths. It may be necessary to readjust the ribbon tension for very narrow or very wide ribbons.

The braking torque of the ribbon mandrels can be adjusted using the red plastic hex bolts [48A] on the ribbon mandrels. Turning clockwise increases the torque. The caps are used to lock the bolts [48B] into place so that they are not adjusted unintentionally.

The entire length of ribbon must run evenly and crease-free between the mandrels. The following parameters are helpful for adjustments:

The ribbon...

- is slack or has creases
- is wound too loosely

→ Increase unwinding/winding torque (turn bolt clockwise).

The ribbon...

- stretches visibly or tears during the printing process
- is not being transported properly

→ Reduce unwinding/winding torque (turn bolt anti-clockwise).

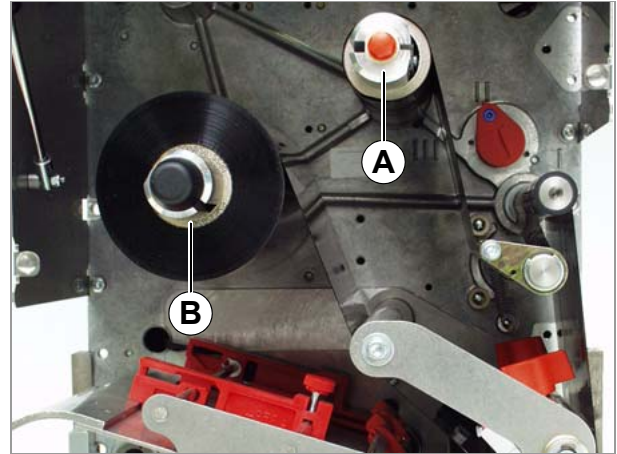

[48] Ribbon mandrels on the DPM/PEM.

- A** Ribbon rewinding mandrel (without cap)
- B** Ribbon unwinding mandrel

## Setting the printhead pressure

**CAUTION!**

Shortened service life of printhead.

→ Always set the weakest printhead pressure that will produce acceptable printing results.

Different material widths and thicknesses affect the contact pressure of the printhead on the print roller.

The contact pressure can be set with an adjusting knob [49A] in 3 stages:

- Stage "I": position for very thin and/or narrow material
- Stage "II": (pre-setting) position for material of medium width/thickness
- Stage "III": position for very thick and/or wide material

Tools: coin or large screwdriver

Setting:

→ Turn the adjusting knob until the arrow of the knob [50A] is positioned over the mark for the desired stage.

▣→ The adjustment knob locks into 3 position.

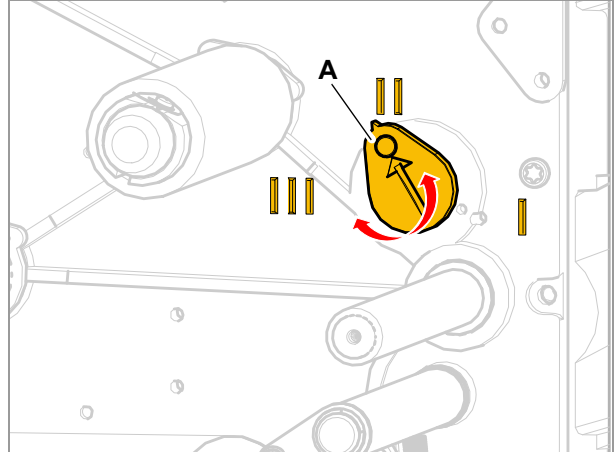
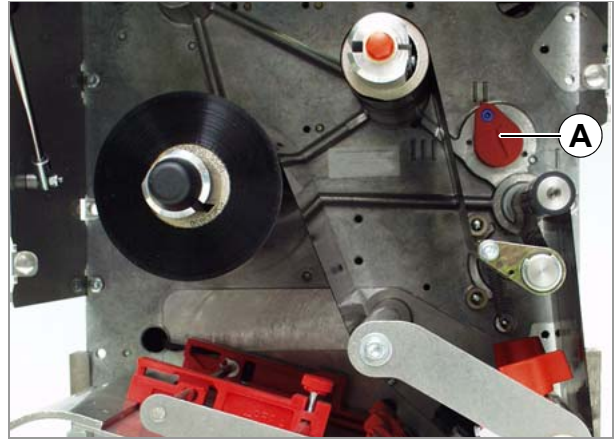

[50] Move the adjustment knob to one of the three locking positions.

## SWITCHING ON/OFF



**WARNING!**

Only by disconnecting the plug from the mains supply is the machine fully disconnected from the supply. Therefore:

- Keep mains connection freely accessible.
- In case of danger switch off the machine and unplug the power cable.

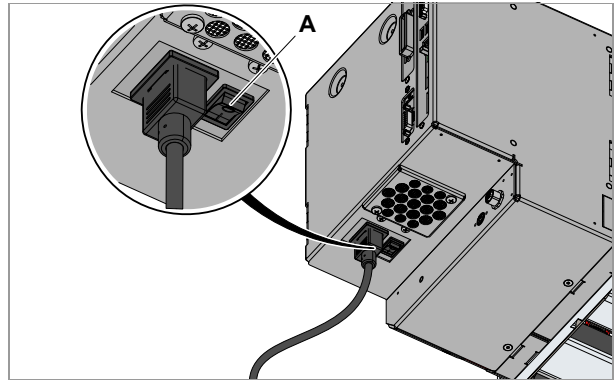

[51] Mains power switch (A) at the DPM/PEM.

### Switching on

1. Move the mains power switch [51A] of the machine to "I" (On).
2. Keep the On/Off switch [52A] on the control panel pressed for approx. 2 seconds.

The machine starts up. Afterwards the machine is in on-line mode. Display:



⚠️ **CAUTION!** - Wait at least 10 seconds between switching the device off and on again, otherwise any modified parameter settings are not saved.

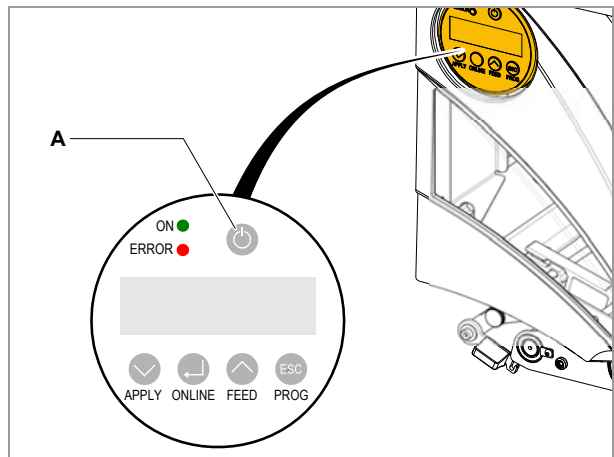

[52] On/Off switch (A) on the control panel.

### Switching off

→ Move the mains power switch [51A] of the machine to "O" (Off).

The machine shuts down.

## SETTING AND MONITORING THE MACHINE

### Settings in parameter menu

► The settings described below are generally included in the print job, in which case they do not need to be made. Manual settings that were made before a print job was transferred will be overwritten by the settings in the print job.

► For further details on setting options in the parameter menu, see section **Parameter menu** on page 44.

#### Label pitch

→ Switch to offline mode.

To measure label pitch automatically:

→ Press the FEED + PROG keys.

The printer moves the label material forward until the two label starting marks have moved through the label sensor. The label pitch determined in this way is displayed and transferred to parameter PRINT PARAMETERS > Materiallength. Parameter PRINT PARAMETERS > Materialtype is set to "Punched".

Display of the measured label pitch:



To enter the label pitch manually:

1. Measure label pitch [53C].
2. Navigate to PRINT PARAMETERS > Materiallength and enter the measured value in millimetres.

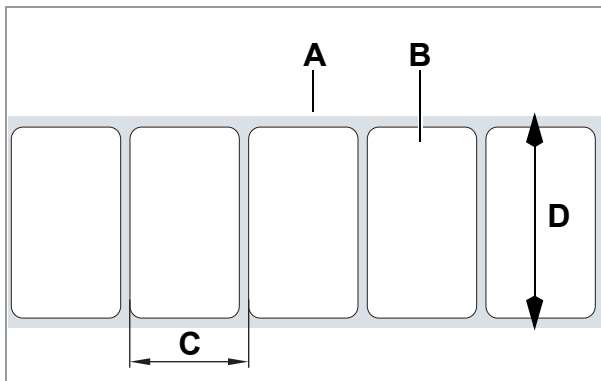

[53] Label material (self-adhesive labels)

- A Label web (backing paper)
- B Label
- C Label pitch
- D Material width

#### Material width

1. Measure the width of the material web [53D] (including backing paper).
2. Enter the measured value in millimetres.

#### Material type

1. Set PRINT PARAMETERS > Materialtype to "Punched".
2. For punched material: Set PRINT PARAMETERS > Light sens. type to "Punched".  
for material with reflex markings (PEM only) to "Reflex".

### Print process

Direct thermal:

→ SYSTEM PARAMETER > Ribbon autoecon. = „Thermal printing“.

Thermal transfer:

→ SYSTEM PARAMETER > Ribbon autoecon. = „Disabled“.

### Reducing use of the printhead

Use of the printhead can be reduced in the thermal direct print process by raising it for extended sections with no printing.

→ SYSTEM PARAMETER > Ribbon autoecon. = „Thermal/headlift“.

### Ribbon saving

→ SYSTEM PARAMETER > Ribbon autoecon. = „On“ or „On Turbo“.

For details refer to chapter „Technical Data“ > **Automatic ribbon economy**  on page 30.

## Monitoring functions

### Missing labels

Normally a missing label on the label belt does not interfere with print operation. Label feed continues running until the start of a label has moved up under the label sensor again.

It may be necessary in some cases, however, to report the missing labels. When function SYSTEM PARAMETER > Miss. label tol. is set, an error message can be generated after one, or not until after several missing labels:

```
Status num:    5001
              No gap found
```

At the same time the machine stops.

### Ribbon reserve

To monitor the ribbon reserve, a critical diameter can be set for the ribbon roll. If the diameter falls below this level, the following - flashing - message appears:

```
FOILØ    X JOBS
```

→ Set SYSTEM PARAMETER > Foil end warning to the preferred ribbon roll diameter in millimetres.

## PRINTING

### Creating print jobs

There are two ways to create a print job:

- Layout software + printer driver
- Text file with Easy-Plug commands

#### Layout software + printer driver

Requirement: A printer driver must be installed on the PC.

Layout software may include any type of software that has a print function (for example text processing). Special label layout software is more suitable, for example NiceLabel <sup>1</sup>.

#### Text file + Easy-Plug

The label layout is described by a sequence of Easy-Plug commands saved in a text file.



### Installing the printer driver

You can find a Windows driver for the DPM/PEM on the documentation CD included with delivery or on our web page <sup>2</sup>. The driver works with the following Windows operating systems: Vista / 7 / 8 / 8.1 / 10 / Server 2008 / Server 2008 R2 / Server 2012 / Server 2012 R2 (the driver will work with Windows XP too, but without any support).

CD installation:

1. Insert the documentation CD in the CD drive of the host PC.  
The CD starts automatically. It contains printer drivers for commonly used Windows operating systems.
2. In the "Printer Documentation" window, click on *Printer Drivers and Label Software > Install > Printer Drivers*.  
The installation wizard is launched.
3. Follow the instructions of the installation wizard.

### Transferring a print job

There are two ways to transfer a print job to the printer:

- via a data cable
- via a memory card

#### Data cable

Requirement:

- The database interfaces of the host PC and printer must be connected with a suitable data cable (Ethernet, RS 232 or USB)
- The database interface must be set accordingly in the printer's parameter menu

To use layout software:

1. Select a suitable database interface in the layout program.
2. Start printing.



---

1) [www.nicelabel.com](http://www.nicelabel.com)

2) [www.novexx.com](http://www.novexx.com)



Sending a command file directly:

→ To open a Windows command line: START > PROGRAM FILES > ACCESSORIES > PROMPT.

To send via serial interface (COM1):

→ `copy testjob.txt com1.`

To send via USB or Ethernet interface:

→ `copy testjob.txt \\ComputerName\ShareName , where`



- ComputerName is the name of the computer (Windows XP: see START > SETTINGS > CONTROL PANEL > SYSTEM > COMPUTER NAME (for example "DM-ECH-0990")).
- ShareName represents the share name for a printer connected to a specific port, such as the USB port or the TCP/IP port (Windows XP: see START > SETTINGS > PRINTERS AND FAXES, right-click on PROPERTIES > SHARE).

### Memory card

Requirements: Memory medium (memory card or USB stick) on which the printjob is stored in folder `\formats`.

1. Connect the memory medium to the printer.
2. Start the printer and switch to standalone mode.
3. Select printjob.

For further details see chapter **Standalone mode**  on page 43.

## STATUS MESSAGES

### Error messages

When a fault occurs, the printer shows an error message on the control panel.

Error messages are based on the following outline:

Print status <sup>a</sup> :	5144 <sup>b</sup>
Rewinder init <sup>c</sup>	

- a) Depending on the cause of the error, "Print Status" or "Queue Status" appears here. "Print Status" = message from the printer controller; "Queue Status" = message from the Easy-Plug Interpreter.
- b) 5144 = The status number. This number is an easy way to identify the message.
- c) "Rewinder init" = Status text; brief description of the error.

To delete an error message:

1. Rectify the cause of the fault. For further details see section [List of error messages](#) on page 66.
2. Press the  key to delete the message.

Error messages that are *not* described below can only be rectified by qualified service personnel.

If an error that is not described here occurs:

1. Press the  key to delete the message.
2. Switch off the device, wait for 30 seconds and switch it on again.

If the error occurs repeatedly:

→ Call in a service technician.



Error messages *not* mentioned here are described in the service manual.

While an error message is being displayed, the "Error" signal output is active.

### List of error messages

5001

#### No gap found

The label sensor has not found a label starting mark (punch or reflex marking).

⊗ Incorrect setting of the material type.

→ Check to ensure the setting of PRINT PARAMETERS > Materialtype matches the label material you are using.

⊗ Incorrect sensor type set (SYSTEM PARAMETER > Label sens. type).

→ Check to ensure the set sensor type matches the label material (punches or reflex markings).

⊗ Incorrect label material inserted (material does not match the setting in PRINT PARAMETERS > Materialtype)

→ Check the label material.

⊗ Incorrect position of label sensor.

→ Check/correct position of label sensor.

⊗ Material guide not set correctly - the label starting marks are running past to the side of the label sensor.

→ Check/correct the material guide setting.

⊗ Label sensor is dirty.

→ Clean the label sensor.

⊗ The sensitivity of the label sensor is set too low. Materials with weak contrast between the material and backing paper or between the reflex marking and the material require increased sensor sensitivity.

→ Increase the sensitivity.

⊗ Punch definition, material type and/or material length are specified incorrectly in the print job.

→ Check the print job.



After confirmation with the online key, the material is automatically fed forward and the system searches for the next punch.

### 5002 **Material end**

There is no more material in the material sensor.

⊗ Label roll is used up.

→ Insert a new label roll.

⊗ Material guide not set correctly - the label starting marks are running past to the side of the label sensor.

→ Check/correct the material guide setting.

### 5003 **Cover open**

⊗ The front cover of the printer is open.

→ Close the front cover.

Closing the front cover automatically deletes the error message.

### 5008 **Foil end**

In thermal printing:

⊗ Ribbon end sensor is *not* switched off.

→ SYSTEM PARAMETER > Ribbon autoecon. = „Thermal printing“.

In thermal transfer print:

⊗ Ribbon roll is used up.

→ Insert a new ribbon roll.

⊗ The core of the ribbon roll is resting loosely on the dispenser.

→ Use a ribbon roll with a suitable core diameter.

→ Adjust the spring plate on the ribbon unwinding mandrel so that the ribbon core is firmly seated.



### 5063 **Press roll**

⊗ (DPM) The lever of the backing paper feed roller (red lever) is open.

⊗ (PEM) The lever of the label material pressure roller (green lever) is open.

→ Close the lever.

Closing the pressure roller automatically deletes the error message.

### 5110 **Foil low**

⊗ The diameter of the ribbon roll has reached the value set under SYSTEM PARAMETER > Foil end warning.

→ Prepare to change the ribbon roll.

# Cleaning and Maintenance

## CLEANING INSTRUCTIONS

### Safety



**WARNING!**

Dangerous situations may arise during maintenance and cleaning work. Accidents may occur due to mechanical or electrical effects if the relevant safety instructions are not observed!

- Switch off the device before cleaning or maintenance and pull out the mains power connecting line!
- Never allow liquid to get into the machine!
- Do not spray the machine with spray bottles or sprays! Use a cloth wetted with cleaning agent.
- Repairs to the machine must only be made by trained service technicians!

### Cleaning agents

**CAUTION!**

Sharp cleaning materials may damage the printer.

- Do not use any cleaning agents or materials that could damage or destroy the paint finish, labelling, display, type plates, electrical component, etc.
- Do not use any scouring cleaning agents or any cleaning agents that could dissolve plastic.
- Do not use acid or alkaline solutions.

Part to be cleaned	Cleaning agent	Order No.
Printhead	Cleaning stylus	95327
	Cleaning paper	5030
Rubber rollers (print roller, pressure roller, etc.)	Roller cleaner	98925
Deviator rollers	Cleaning solvent, alcohol, isopropyl alcohol	--
	Label release spray	90073
Housing	Standard commercial neutral cleaning agent	--

[Tab. 18] Recommended cleaning agents:

### Cleaning interval

→ Clean machine regularly.

The frequency depends on the following factors:

- Operating conditions
- Daily operating duration
- Label material/ribbon combination used

## GENERAL CLEANING

Dust particles are especially likely to accumulate in the area of the print mechanics.

- Remove dust particles with a soft brush or a vacuum cleaner.
- Clean the housing with a cloth and a standard commercial neutral cleaner.

## PRINTHEAD

### General notes

The thermal head [55A] and its holder [55C] are referred to together as the printhead [54].

**CAUTION!**

Danger of irreversible adjustment of the printhead position.

→ Never loosen the screws [54A] on the printhead.

→ If a print head ever becomes misaligned, remove the entire printhead and send it in to us for realigning.

**CAUTION!**

Electrostatic discharge or contact with sharp edges can damage the printhead!

→ Always protect the printhead against electrostatic discharge when performing maintenance and cleaning work!

→ Never touch the thermal strip [55B] with bare hands!

→ Never contact the thermal strip with sharp objects!

⚡ If you do not have suitable ESD protective gear (ESD arm band, ESD shoes, etc.), touch a grounded object (e.g. radiator) to discharge any static electricity before touching the printhead!

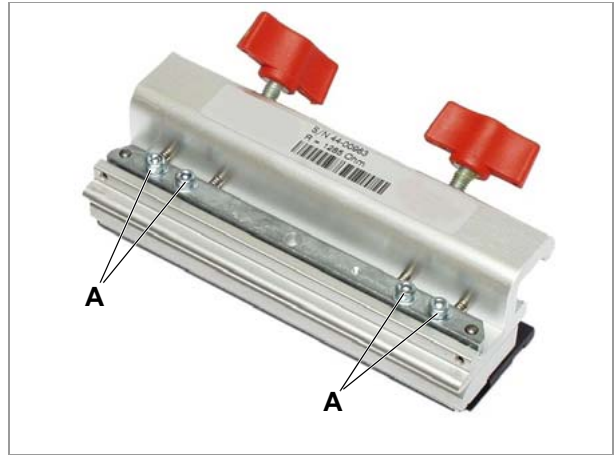

[54] Printhead

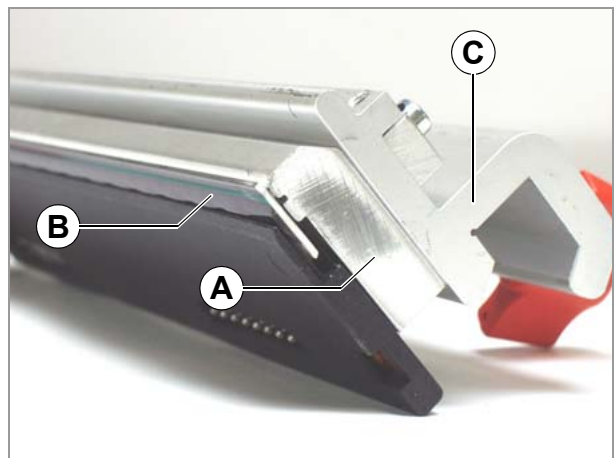

[55] Printhead

- A** Thermal head
- B** Thermal strip
- C** Holder for thermal head

## Cleaning the printhead

**WARNING!**

Burn hazard! The printhead can become hot during operation.

→ Be careful whenever touching the printer.

Paper dust and coloured particles from the thermal transfer ribbon may collect on the printhead during printing. Over time, this can significantly impair the printing quality in the following ways:

- Contrast differences in label
- Bright strips in printing direction

### Cleaning interval

- Thermal transfer print: every time the ribbon roll is changed
- Direct thermal print: every time the label roll is changed

### Preparing the printhead

1. Switch off the machine.
2. Unplug the mains power connecting line.
3. Remove the label material and ribbon.
4. Remove both wing bolts [56A] until the printhead can be swivelled up.
  - ▮ Before swivelling the printhead up, shift it about 1 cm towards the middle of the axle.
  - ▮ If the printhead is not at the limit stop on the side, mark the position on the axle in advance.
5. Rotate the printhead up [57].

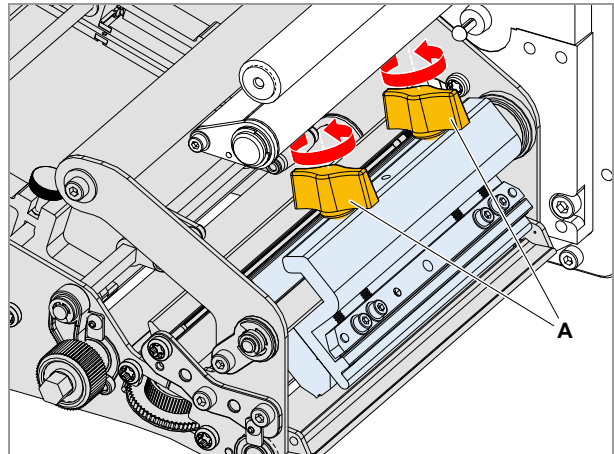

[56] Wing screws (A) on the printhead.

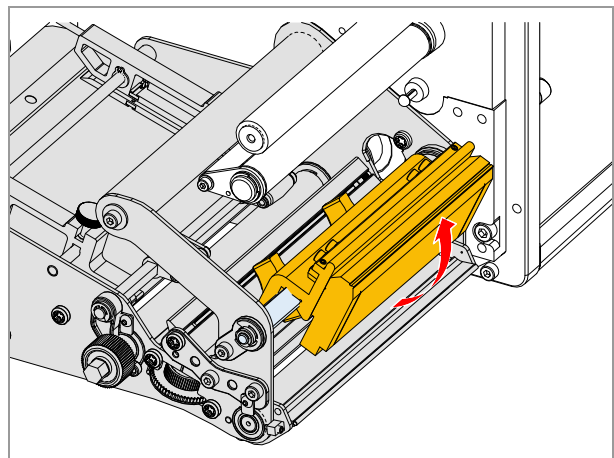

[57] Rotate the printhead up.

**Cleaning with a cleaning stylus**

→ Run the stylus many times back and forth across the thermal strip [58A] of the printhead.

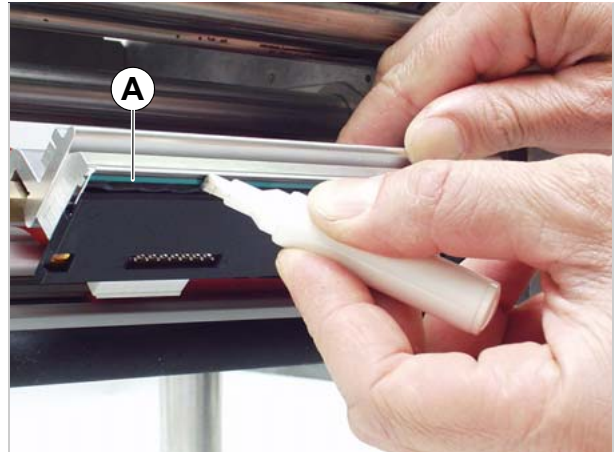

[58] Clean the printhead with the cleaning stylus.  
A Thermal strip

**Using a cleaning strip**

→ Rub the rough side of the cleaning strip [59A] many times back and forth across the thermal strip of the printhead. As you do so lightly press the cleaning strip with your hand.

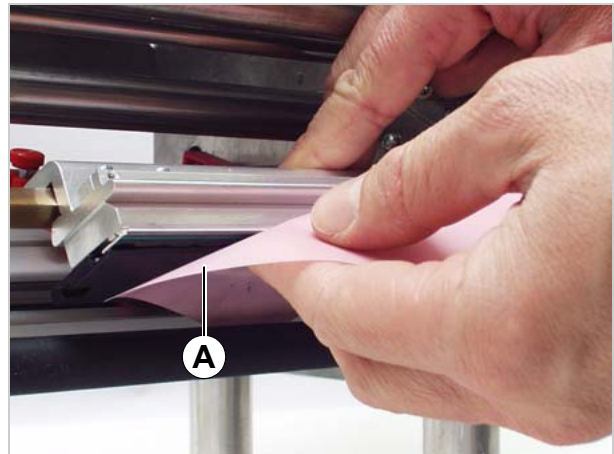

[59] Clean the printhead with the cleaning strip.

**Using alcohol:**

→ Moisten a lint-free cloth with alcohol and wipe the cloth across the thermal strip of the printhead [60].

**Fasten the printhead in place again**

1. After cleaning, move the printhead holder back to its former position and retighten the wing bolts.
  - ▮▮▮ The wing bolts must press against the chamfer of the square axle.
  - ▮▮▮ Ensure that the printhead is properly positioned relative to the label edges.

Factory set printhead position: at the limit stop on the inside of the black plastic bushing.
2. Before turning on the unit, always check whether the printhead cable has been properly plugged. If not, be sure to plug it in correctly.



[60] Clean the printhead with alcohol.



## Replacing printheads

The printhead can only be replaced as a complete unit as shown in [63A].



**WARNING!**

Burn hazard! The printhead can become hot during operation.

→ Be careful whenever touching the printer.

1. Switch off the machine.
2. Remove the mains power connecting line.
3. Remove the material and ribbon.
4. Pull out both plugs on the printhead [61].
  - ▮▮▮▮ After switching off machine, wait at least 3 minutes before unplugging the printhead cable.
5. Remove both wing bolts until the entire printhead can be removed from the pressure shaft.
  - ▮▮▮▮ If the printhead is not at the limit stop on the side, mark the position on the axle in advance.
6. Install the new printhead at the former position and retighten the wing bolts.
 

Factory set printhead position: at the limit stop on the inside (black plastic bushing).

  - ▮▮▮▮ The wing bolts must press against the chamfer of the square axle.
  - ▮▮▮▮ Pay close attention to the position of the printhead in relation to the edge of the label (to the marking or up to the limit stop).
7. Plug the printhead cables back into the printhead. Continued on next page.
8. The resistance of the new printhead can be entered using the SYSTEM PARAMETER > Head resistance parameter.
  - ▮▮▮▮ The resistance is given on the printhead sticker [63B].

**CAUTION!**

Entering the wrong resistance can damage the printhead!

→ Enter the resistance that is applied against the *installed* printhead.

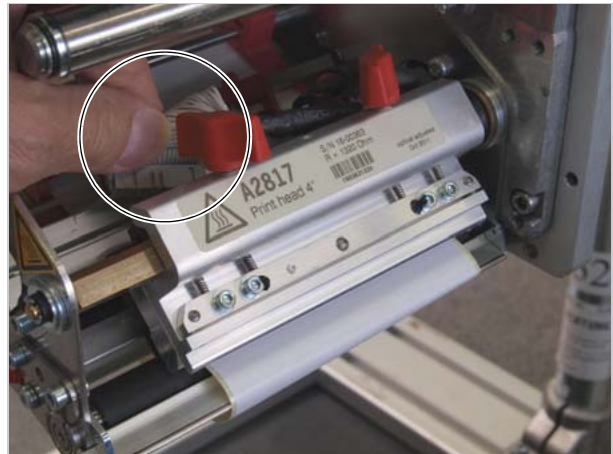

[61] Pull out the connection cables.



[62] Remove the printhead.



[63] Printhead (A) with resistance identification (B); in this case: 1221 Ohm.

## Testing the printhead

The printer is equipped with a test function that checks the functionality of each single dot.

### Dot check with status report

→ Open SERVICE FUNCTIONS > Head dot test.

A status report is generated after the dot check to provide information about the number and position of any dots that may be faulty.

### Dot check with display message

→ Press the APPLY + FEED keys.

Message indicating a faulty dot:

```
Status num:    5103
             Dot defect
```

▣▣▣▣ If all dots are fault-free, no message appears.

▣▣▣▣ If an error message occurs, the current print job is stopped.

### Duration of the dot check

The entire check can last from 10 s to several minutes depending on the printhead (the wider the printhead and the more defective dots, the longer the duration) of the check.

### Interrupting the dot check

CAUTION!  
Danger of destroying individual dots on the printhead.  
→ Never quit a dot check by turning off the unit!

→ Press the FEED + CUT+ ONLINE keys.

▣▣▣▣ To cancel the dot check in situations where it is absolutely necessary, reset the unit!

## RUBBER ROLLERS

The rubber rollers on the DPM/PEM can be cleaned from the bottom of the machine without any additional assembly work. The ribbon roller is freely accessible while the cover is open and the ribbon is removed [64].

Cleaning the rollers:

1. Switch off the machine.
2. Remove the mains power connecting line.
3. Remove the material and/or ribbon.
4. Wipe off the rollers with a dust-free cloth and roller cleaner.
  - ▮▮▮▮ Rotate the roller step for step until it is completely clean.

**CAUTION!**

Danger of damaging the roller.

→ Never use knives or sharp objects to clean the rollers!

▮▮▮▮ It is also possible to clean the print roller from the front. To do this remove the printhead.

See **Replacing printheads** □ auf Seite 74.

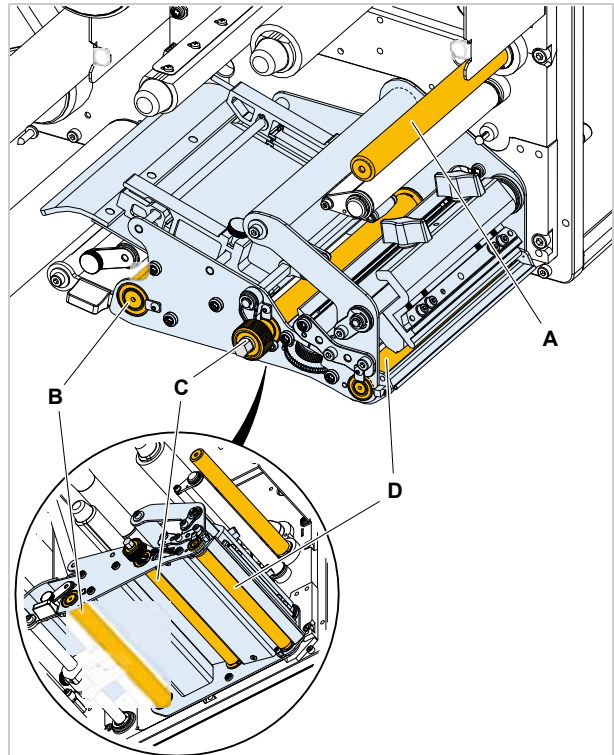

[64] Positions of the rubber rollers at the DPM:

- A Print roller
- B Brake roller
- C Feed roller
- D Ribbon feed roller

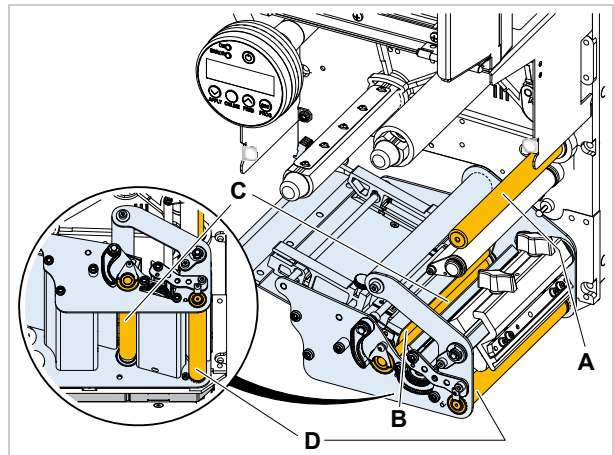

[65] Positions of the rubber rollers at the PEM:

- A Feed roller
- B Print roller
- C Pressure roller
- D Ribbon feed roller

## BACKING PAPER DEVIATOR ROLLER (DPM)

Clean the material deviator roller, if it is dirty with residues of adhesive, labels or something similar:

1. Switch off the machine.
2. Pull out the mains plug.
3. Remove material.
4. Screw out the thumb screw [66A] and take off the locking plate [66B].
5. Pull the deviator roller off its axle [67].
6. Clean the deviator roller using cleaning fuel or adhesive removing solvent, depending on the degree of pollution.
7. Put the deviator roller back on the axle; apply locking plate and thumb screw

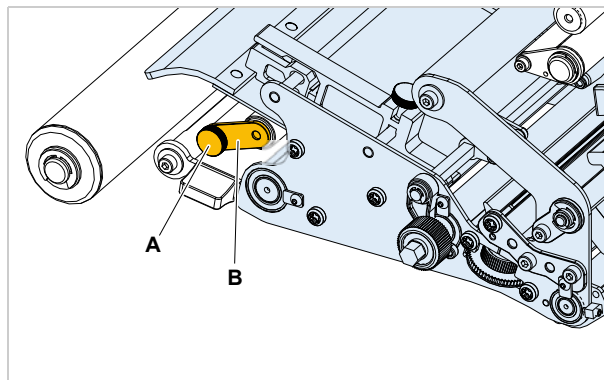

[66] Remove the thumb screw (A).

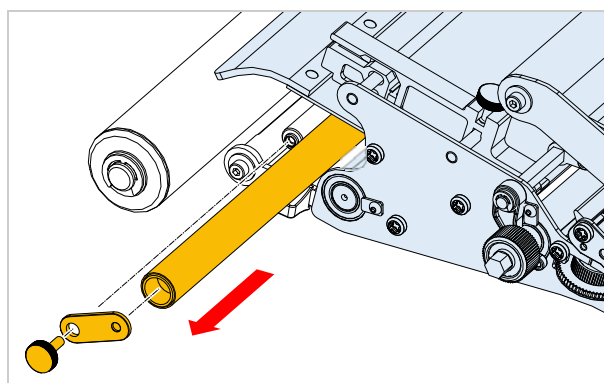

[67] Pull out the deviator roller.

## SENSORS

Clean the sensors regularly to remove any material residue and dust. The cleaning intervals depend on the materials in use.

### Cleaning the punch sensor

To access the punch sensor, first remove the guiding section:

1. Switch off the machine.
2. Remove the mains power connecting line.
3. Remove material and ribbon.
4. Remove the bolts [68A] (using 3 mm Allen key).
  - ▮▮▮ At the PEM, the guiding section is attached with only one screw.
5. Remove guide section [68A] from side.
6. Write down the position of the sensor thumb wheel [69B].
7. Turn the thumb wheel to move the sensor fork all the way to the outside .
8. Using compressed air, blow out the gap [69A] in the sensor arm (canned air is available as an accessory).
  - ▮▮▮ If the sensor is heavily contaminated, use cleaning solvent and a lint-free cloth to clean the sensor.
9. Reinstall the guiding section and fasten it with the bolts.
  - ▮▮▮ Push the guiding section with the groove [70A] over the rear guide tab on the sensor fork [70B].
10. Move the sensor back to its original position.

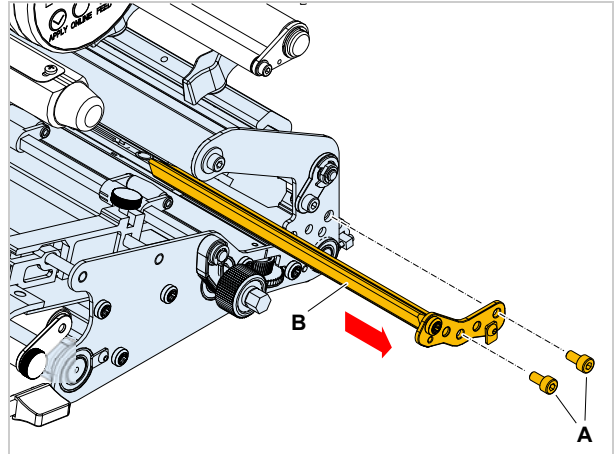

[68] Removing the guiding section (B).

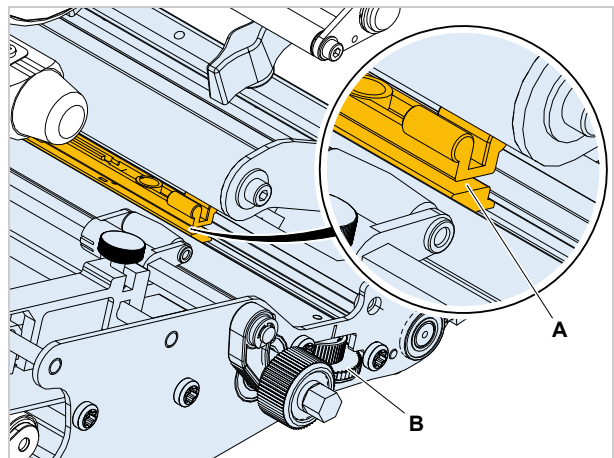

[69] Sensor fork (A).

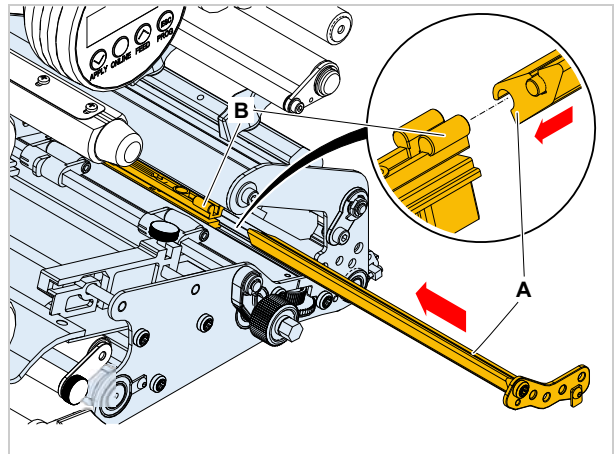

[70] Guiding tab (B) at the sensor fork.

## Cleaning the material end sensor

The material end sensor [71A] is located inside the material guide. The sensor must be cleaned of material and dust residue regularly. The cleaning intervals depend on the material in use.

→ Clean the sensor arm using compressed air (canned air is available as an accessory).

▣▣▣▣ If the sensor is heavily contaminated, use cleaning solvent and a lint-free cloth to clean the sensor.

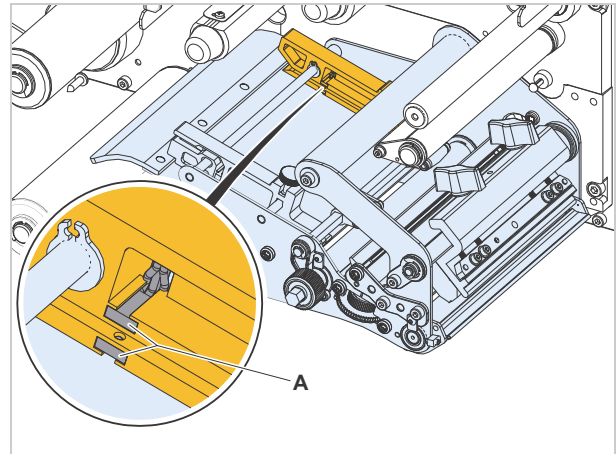

[71] Material end sensor (A) in the inside material guide.

## CLEANING THE RIBBON PATH

All parts which come into contact with the ribbon [72] must be cleaned on a regular basis. The following minimum distances apply:

- Once per week  
or
- Every 5000 m of ribbon

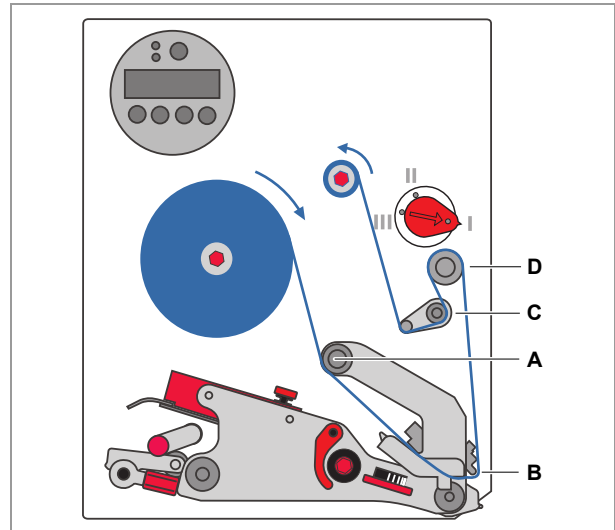

[72] Parts where ribbon residue gathers:

- A** Ribbon roller
- B** Deflector roller + stress relief
- C** Deflector
- D** Deflector tab on printhead



## REPLACING THE FILTER LINER

**CAUTION!**

A clogged dust filter can result in overheating, thereby causing a machine failure.

→ Replace the filter liner on the fan regularly.

The replacement interval for the filter liner must be defined according to the specific circumstances. The following factors determine the frequency:

- Dust content of the air
- Operating duration

Tool: Cross-head screw driver, medium size

The filter liner can be cleaned by blowing it out with compressed air or by washing it out.

To change the filter liner:

1. Unscrew the 2 screws [74A]. Remove the filter housing [74B].
2. Replace the liner [74C] (part number for 1 piece: A2236).
3. Press the filter housing to the filter. Retighten the 2 screws [74A].

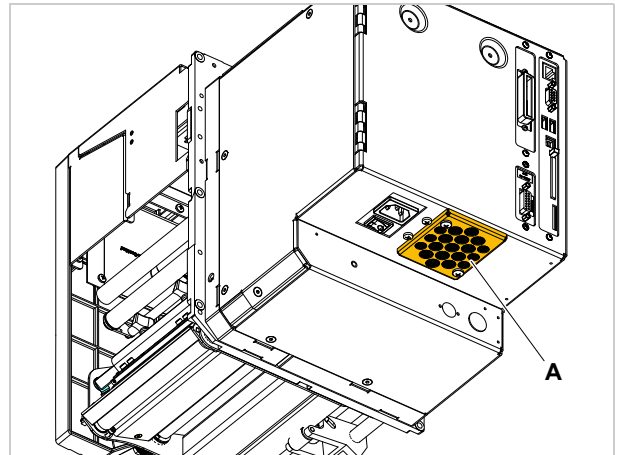

[73] Dust filter at the DPM

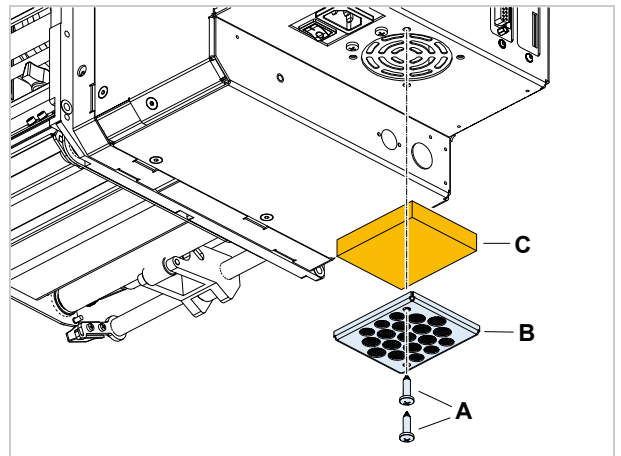

[74] Filter housing removed.



# EU Declaration of Incorporation

(Translation of original version)

We, Novexx Solutions GmbH  
 Ohmstraße 3  
 D-85386 Eching  
 Germany

hereby declare that the partly completed machine designated below has been designed and built in such a way as to be in conformity with the safety and health protection requirements of directive 2006/42/EC, annex I, which are marked „fulfilled“ in the following table „Appendix regarding the Declaration of Incorporation“.

The special technical documents in accordance with appendix VII part B of directive 2006/42/EC have been created. We undertake to forward the special technical documentation in respect of the partly completed machine to national authorities at their request. We shall submit them by means of electronic data carrier.

The partly completed machine designated herein is furthermore in compliance with the provisions of directive 2014/30/EU (EMC) and directive 2011/65/EU (RoHS).

The designated partly completed machine must not be placed in operation until it has been determined that the machine in which the partly completed machine has been installed is in compliance with the provisions of directive 2006/42/EG.

<b>Models</b>	DPM / PEM
<b>General designation</b>	Label print & apply system
<b>Trade name</b>	Avery Dennison
<b>Serial number</b>	Consecutive number (6 digits) starting with 100000
<b>Applicable EU directive</b>	2006/42/EG (Machinery) 2014/30/EU (EMC) 2011/65/EU (RoHS)
<b>Applied harmonized standards, especially</b>	EN ISO 12100:2010 EN 415-2:1999 EN 60950-1:2006/A12 : 2011 EN 55022 : 2010 class A EN 61000-6-2 : 2005 EN 61000-3-2/A2 : 2009 EN 61000-3-3 : 2008
<b>The person authorized to compile technical documents</b>	Novexx Solutions GmbH (for address see above)

Eching, 1.11.2015

Manfred Borbe (Director)

## APPENDIX REGARDING THE DECLARATION OF INCORPORATION

List of the essential health and safety requirements applied and fulfilled for the product named in the declaration of incorporation, relating to the design and construction of machinery.

Number Annex I	Designation	Not applicable	Fulfilled	Remark
<b>1.1</b>	<b>General remarks</b>			
1.1.2.	Principles of safety integration		X	
1.1.3.	Materials and products		X	
1.1.4.	Lighting	X		
1.1.5.	Design of machinery to facilitate its handling		X	
1.1.6.	Ergonomics	X		
1.1.7.	Operating positions	X		
1.1.8.	Seating	X		
<b>1.2.</b>	<b>Control systems</b>			
1.2.1.	Safety and reliability of control systems		X	
1.2.2.	Control devices		X	
1.2.3.	Starting		X	
1.2.4.	Stopping			
1.2.4.1.	Normal stop		X	
1.2.4.2.	Operational stop		X	
1.2.4.3.	Emergency stop		X	
1.2.4.4.	Assembly of machinery		X	
1.2.5.	Selection of control or operating modes	X		
1.2.6.	Failure of the power supply		X	
<b>1.3.</b>	<b>Protection against mechanical hazards</b>			
1.3.1.	Risk of loss of stability		X	
1.3.2.	Risk of break-up during operation		X	
1.3.3.	Risks due to falling or ejected objects		X	
1.3.4.	Risks due to surfaces, edges or angles		X	
1.3.5.	Risks related to combined machinery	X		
1.3.6.	Risks related to variations in operating conditions	X		
1.3.7.	Risks related to moving parts		X	
1.3.8.	Choice of protection against risks arising from moving parts			
1.3.8.1.	Moving transmission parts		X	
1.3.8.2.	Moving parts involved in the process			DPM only: Requires protective device <sup>a</sup>
1.3.9.	Risks of uncontrolled movements		X	
<b>1.4.</b>	<b>Required characteristics of guards and protective devices</b>			
1.4.1.	General requirements			DPM only <sup>a</sup>
1.4.2.	Special requirements for guards			
1.4.2.1.	Fixed guards	X		
1.4.2.2.	Interlocking movable guards			DPM only <sup>a</sup>
1.4.2.3.	Adjustable guards restricting access	X		
1.4.3.	Special requirements for protective devices	X		
<b>1.5.</b>	<b>Risks due to other hazards</b>			
1.5.1.	Electricity supply		X	
1.5.2.	Static electricity		X	
1.5.3.	Energy supply other than electricity		X	

Number Annex I	Designation	Not applicable	Fulfilled	Remark
1.5.4.	Errors of fitting		X	
1.5.5.	Extreme temperatures		X	
1.5.6.	Fire		X	
1.5.7.	Explosion	X		
1.5.8.	Noise		X	
1.5.9.	Vibrations	X		
1.5.10.	Radiation		X	
1.5.11.	External radiation		X	
1.5.12.	Laser radiation	X		
1.5.13.	Emissions of hazardous materials and substances	X		
1.5.14.	Risk of being trapped in a machine	X		
1.5.15.	Risk of slipping, tripping or falling		X	
1.5.16.	Lightning	X		
<b>1.6.</b>	<b>Maintenance</b>			
1.6.1.	Machinery maintenance		X	
1.6.2.	Access to operating positions and servicing points		X	
1.6.3.	Isolation of energy sources		X	
1.6.4.	Operator intervention		X	
1.6.5.	Cleaning of internal parts	X		
<b>1.7.</b>	<b>Information</b>			
1.7.1.	Information and warnings on the machinery		X	
1.7.1.1.	Information and information devices		X	
1.7.1.2.	Warning devices	X		
1.7.2.	Warning or residual risks		X	
1.7.3.	Marking of machinery		X	
1.7.4.	Instructions		X	
1.7.4.1.	General principles for the drafting of instructions		X	
1.7.4.2.	Contents of the instructions		X	
1.7.4.3.	Sales literature		X	

a) Installation by the system integrator

**Novexx Solutions GmbH**  
Ohmstraße 3  
85386 Eching  
Germany  
☎ +49-8165-925-0  
[www.novexx.com](http://www.novexx.com)

**NOVEXX**   
SOLUTIONS