

USER MANUAL

ALS 104

Labeler

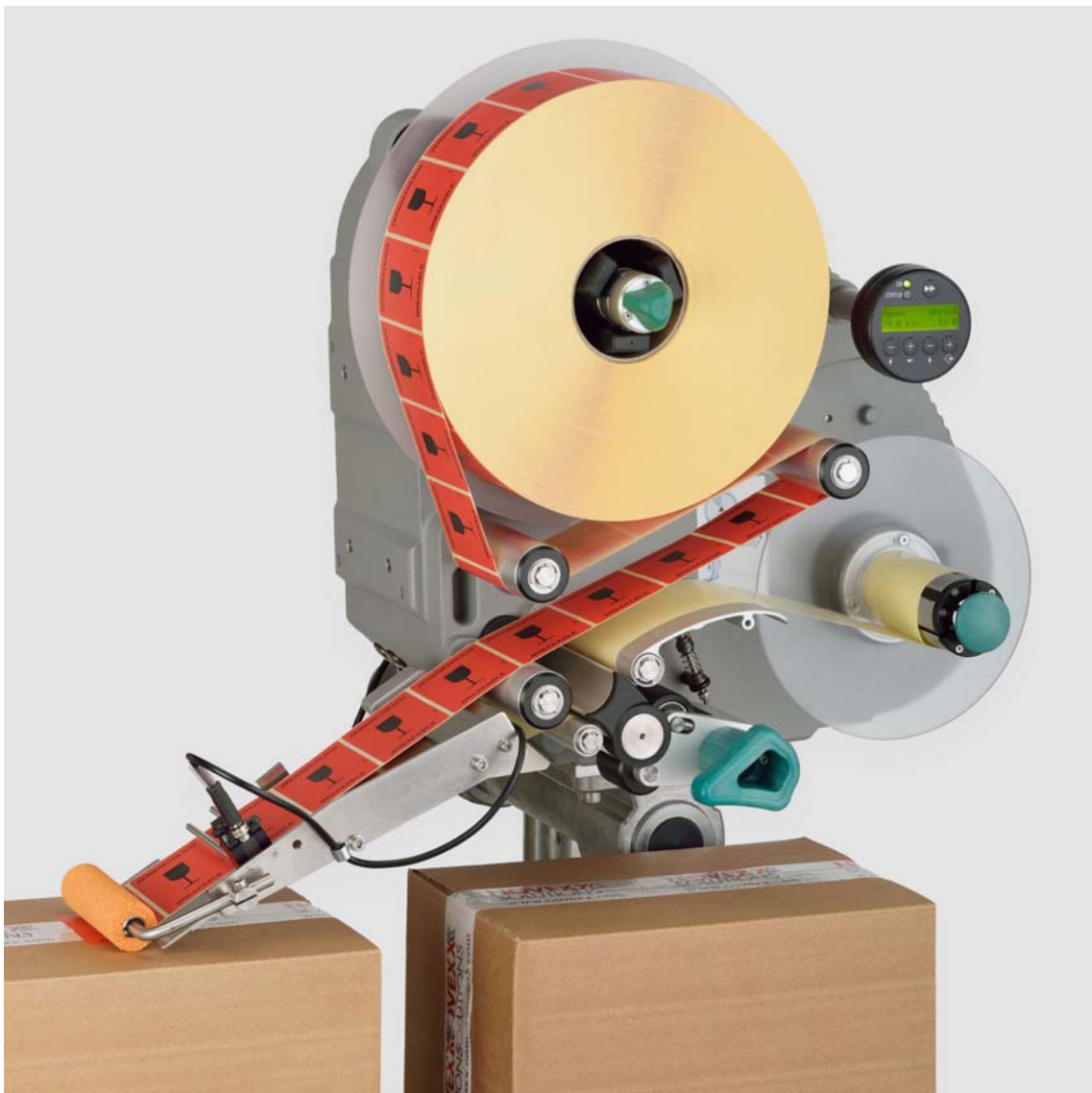

Contents

Please note -5

- General notes -5
 - Validity and binding effect of this manual -5
 - Illustrations and descriptions -6
 - Safety instructions -8
 - Information and qualifications -8
 - Operational safety of the unit -9
 - Before beginning production -11
 - Warning notes on the unit -12
- 12**

Product description -13

- Overview -13
 - Components -13
 - Control panel -15
 - Connection arrangement -16
 - Mode of operation -17
 - Design models -19
- Technical specifications -20
 - Characteristics -20
 - Labels -20
 - Label sensor -20
 - Power supply -20
 - Electronics -21
 - Internal Interfaces -21
 - Status messages, test functions -21
 - Dimensions -22
 - Ambient conditions -22
 - Integration -22
 - Certificates/Markings -22
- Options -23
 - External control panel -23
 - Fixed dispensing edge -23
 - Swivelling dispensing edge -23
 - Spring-loaded dispensing edge -23
 - Pneumatic dispensing edge -24
 - V-shape dispensing edge -24
 - Adjustable dispensing edge holder -24
 - Outer Diameter control sensor -25
 - Dust/Splash guard -25
 - Additional material guide disk -25
 - Printer -26
 - Narrow label spring kit -26
- Operating modes -27

- Dispensing mode -27
- Configuration mode -28
- Function overview -29
- Function descriptions -30

Before operation -32

- Electrical connections -32
 - Power supply standard machine -32
 - Connecting sensors -34
- Inserting label material -35
 - Inserting a label roll -35
 - Threading the label web -36
- Mechanical settings -39
 - Adjusting the unwinder's core diameter -39
 - Positioning the pressure roller -39
 - Calibrating the label sensor -40
 - Setting the dancer arm restoring force -40

Operation -41

- Start-up and shutdown -41
 - Turning on the unit -41
 - Starting label dispensing -41
 - Stopping the dispensing process -41
- Configuration and monitoring -42
 - Function menu settings -42
 - Monitoring functions -45

After operation -46

- Maintenance and cleaning -46
 - Changing fuses -46
 - Cleaning agents -47
 - Regular maintenance -48

Operational failures -49

- Error messages -49
 - Error messaging -49
 - List of error messages -49

EU Declarations -1

- EU Declaration of Conformity -1
 - EU Declaration of Incorporation -2
 - Appendix regarding the Declaration of Incorporation -3

Please note

GENERAL NOTES

Validity and binding effect of this manual

Contents

The complete operating manual for the ALS 104 labeler consists of the following parts:

Manual	Target group	Medium	Availability
User manual	Operating personnel	Printed	Comes with machine
Installation manual	Service personnel	User Docu-CD	
Service manual		PDF file	NOVEXX Solutions
Spare parts catalogue			Partner Portal 

This operating manual refers exclusively to the machine types listed above. It is written for the purpose of ensuring professional usage and calibration of the unit.

Prerequisites for the use and adjustment are the professional installation and configuration of the unit.

- For information about the required qualification, see section [Information and qualifications](#)  on page 8.
- For information about installation and configuration, see the service manual.

For any technical questions you may have that are not described in this manual, see:

→ The service manual of the labeler

or

→ Request a technician from one of our sales partners.

- Our sales representatives are available to assist you, particularly with configuring the unit as well as in the case of malfunctions.

Technical status

Technical state: 01/2007

Software versions: 3.21 (Frontend), 1.85 R02 (Drive)

Liability

NOVEXX Solutions reserves the right:

- To make modifications to construction parts, components and software, as well as to employ comparable components in place of the parts specified, in keeping with technical advances.
- To modify information in this document.

No commitment will be made to expand these modifications to include any units delivered earlier.

Copyright

NOVEXX Solutions holds all rights to this manual and its appendices. Reproduction, reprinting or any other types of duplication, even of portions of this manual, may only be carried out with express written consent.

Printed in Germany

Manufacturer

Novexx Solutions GmbH

Ohmstrasse 3

85386 Eching

Germany

Phone: +49-8165-925-0

Fax: +49-8165-925-231

www.novexx.com

Illustrations and descriptions**Signs and symbols**

Various information types are indicated in different ways within the document in order to simplify readability and comprehension.

Sentences starting with an arrow are instructions and guidelines.

→ Perform the instructions one after another in the specified order.

The following information begins with a dash:

- Lists
- Mode descriptions
- Descriptions of prior steps
- Prerequisites for following actions

Dangers and risk notes

Important directions that you must absolutely observe are particularly emphasized:

**WARNING!**

A warning refers to risks that can lead to serious injury or death! The warning contains safety measures to protect the relevant persons.

→ Always follow the instructions.

CAUTION!

A caution indicates risks that can lead to property damage or injuries to persons (minor injuries). The caution note contains instructions for preventing damages.



→ Always follow the instructions.

Figures

Texts are accompanied by figures where necessary. Figures are indicated using figure numbers in [square brackets]. A capital letter after a figure number, for example [12A], refers to a specific section of the figure.

Generally, the labeler shown is a right-handed version. The left-handed version is only shown where it is necessary to differentiate between the two.

Button symbols

- The buttons of the control panel are depicted as symbols.
- The symbols are depicted with a '+' (PLUS SIGN) between them if more than one button is to be pressed.  + 

Functions

Functions are displayed in grey in the text with the following structure, MENU NAME > Function name.

Supplementary information

The expert symbol indicates actions that are only to be performed by qualified and specially trained personnel.



The information symbol indicates notes and recommendations, as well as additional information.



Equipment:

- Equipment, for example lubricants or cleaning agents

SAFETY INSTRUCTIONS

Information and qualifications

Ensure the required qualifications are met

- Ensure that only trained and authorized personnel operate, configure and service the unit.
- Only allow qualified and well-trained expert personnel or service technicians to perform configurations.
- The responsibilities with regard to operation, configuration and maintenance should be clearly defined and consistently maintained.
- In addition, personnel should also be instructed on a regular basis in matters of occupational safety and environmental protection.

Qualification for operation

The instruction of personnel using the unit must ensure that:

- The operating personnel can use the unit on their own and safely.
- The operating personnel can remedy small operational disruptions on their own.
- At least two people must be instructed in the unit's usage.
- Enough label material must be provided for testing and instructional purposes.

Qualification for system integrators and service technicians („service personnel“)



Knowledge required to install the print dispenser and perform service work must be demonstrated through appropriate qualification. Only service personnel with technical training are able to assess the tasks to be performed and recognise potential dangers.

- Knowledge acquired through technical training in mechanics and electronics (for example in Germany the training to become a mechatronics engineer).
- Participation in a technical training course for the corresponding labeler offered by the manufacturer.
- The service personnel must be acquainted with the functionality of the labeler.
- The system integrator must be acquainted with the functionality of the of the system into which the labeler is being integrated.

Tasks	System integrator	Operator	Service technician
Install the machine	X		
Connect	X		
Make settings	X		
Switch on/off	X	X	X
Insert/change material/ribbon	X	X	X
Application-related settings	X	X	X
Rectify minor operating faults ¹	X	X	X
Clean the machine		X	X
Rectify major operating faults ²			X
Settings to the electronics/ mechanics			X
Repairs			X

[Tab. 1] An example of the distribution of tasks among different qualified personnel

Tasks	System integrator	Operator	Service technician
Manual:	Service manual	Operating Manual	Service manual, spare parts catalogue

[Tab. 1] An example of the distribution of tasks among different qualified personnel

- 1) For example faults when detecting labels
- 2) For example incorrect labelling

Follow the instructions

WARNING!

Safe and efficient operation of the labeler can only be guaranteed if you observe all necessary information.

- Before operating the unit, read the operating instructions and all other notes carefully.
- Observe the additional safety and warning notes on the labeler.
- Only permit competent people to operate and configure the labeler.

Product liability and warranty claims can only be asserted if the unit was operated in accordance with the directions in the manual.

Keep the product information at hand

With respect to this manual:

- It should be kept at the location where the unit is installed and be available to the operator.
- It should always be legible.
- If the unit is sold, the manual should be made available to the new owner.
- The safety and warning notes affixed to the unit itself must be kept clean and legible. Missing or damaged signs must be replaced.

Operational safety of the unit

Proper usage

The labeler described here is designed for dispensing and applying pre-printed self-adhesive labels to products or packages.

The label material that is used must be punched and in roll shape. Punched means that the labels adhere individually, separated by punchings, on a carrier material. The labels must only adhere strongly enough so that they will come loose when the material is deflected over a sharp edge.

Usually, the labeler is integrated into a superordinate system, e.g. a packaging system, by a system integrator. The labels are typically attached to products, which are moved by an automatic conveyor.

Any other type of or more extensive application will be considered non-intended use. NOVEXX Solutions shall assume no liability for damage resulting from non-intended use of the machine.

The system integrator must install the machine with suitable equipment to protect operating personnel from danger; for example, the danger of the hands or fingers being crushed by reaching in between the product and the dispensing edge.

**WARNING!**

Improper usage of the unit can cause accidents, property damage and production downtime!

- Only use the unit in accordance with the instructions specified in this manual.
- Do not operate the unit without the required safeguards.
- Only configure the unit in accordance with this manual and with the required care.
- Only use original accessories.
- Do not make any modifications or alterations to the unit.
- Repairs to the device may only be performed by authorised specialists who are aware of the risks involved.

Protection against injuries by electrical current**WARNING!**

The machine operates using mains voltage! Touching live electrical parts may expose you to hazardous electrical currents and may lead to burns.

- Only operate the unit once the housing has been reassembled properly.
- The machine may only be connected by authorised specialists, who are aware of the risks involved.
- Only link the unit to devices that fulfil the SELV (safety extra-low voltage) circuit requirements specified in EN 60950.
- Make sure that the power switch at the machine is accessible.

The unit is not protected against splashing water in its standard model ¹.

- Keep the unit dry.
- Before cleaning, switch off the unit and remove the power cable from the socket.
- If liquids have penetrated the unit, switch it off and disconnect or unplug the power cable immediately. Inform a service technician.

1) Exception: Machines with special equipment for dust/splash protection are protected against splashing water.

CAUTION

A too high or low supply voltage can damage the unit.

- Only operate the device using the system voltage indicated on the nameplate.
- Ensure that the mains voltage set on the unit is the same voltage as that provided by the electricity supplier.

Protection against injuries by mechanical action**WARNING!**

Risk of injury due to moving and rapidly rotating parts!

- Maintain a safety clearance from the machine when it is in operation.
- Never reach into a machine that is running.
- Switch off the machine before making any mechanical settings.
- Keep clear of the area around moving parts even when the machine is stopped if there is any possibility of the machine starting up.

Dancer levers work by spring tension and may snap back if the track tension of the label material suddenly decreases.

- Always keep clear of the range of motion of the dancer levers.

Entanglement hazard!

- When working in the vicinity of machines in operation, do not wear ties, loose clothing items, jewellery, wrist watches or similar objects on your body.
- Long hair must be kept in a hair net and must not be worn loose.

Crushing hazard on the dispensing edge due to products on the conveyor equipment!

- Never reach between the product and the dispensing edge while the unit is in operation or ready for operation.
- Never reach behind the safety guard or remove it while the unit is in operation.

Tripping hazard!

- Lay the connection cable and pneumatic hoses (if fitted) so that no one can trip over them.

Danger of injury caused by falling label roll!

- Wear safety shoes.

Before beginning production**Due diligence of the operating company and the service technician**

- Ensure that the following prerequisites are fulfilled in accordance with the service instructions:
 - The machine is installed properly and configured in accordance with the guidelines.
 - All required safety mechanisms have been installed.
 - The unit has performed at least one successful test run.
 - The unit is connected to the power supply.
- The users have the required personal protective equipment, for example, a hairnet. Ensure that the protective equipment is utilised correctly.

Due diligence of the user

- Check that the safety installations are working properly.
- Inspect the machinery for any visible damage. Report any ascertained defects immediately.
- Use the required personal protective equipment correctly, for example, wear a hairnet.
- Remove any unnecessary materials and objects from the operating area of the unit.
- Ensure that only authorised persons are within the operating range of the machine.
- Ensure that starting up the machine will not injure anyone.

Warning notes on the unit



CAUTION!

Warning notes on the unit represent important information for the personnel using it.

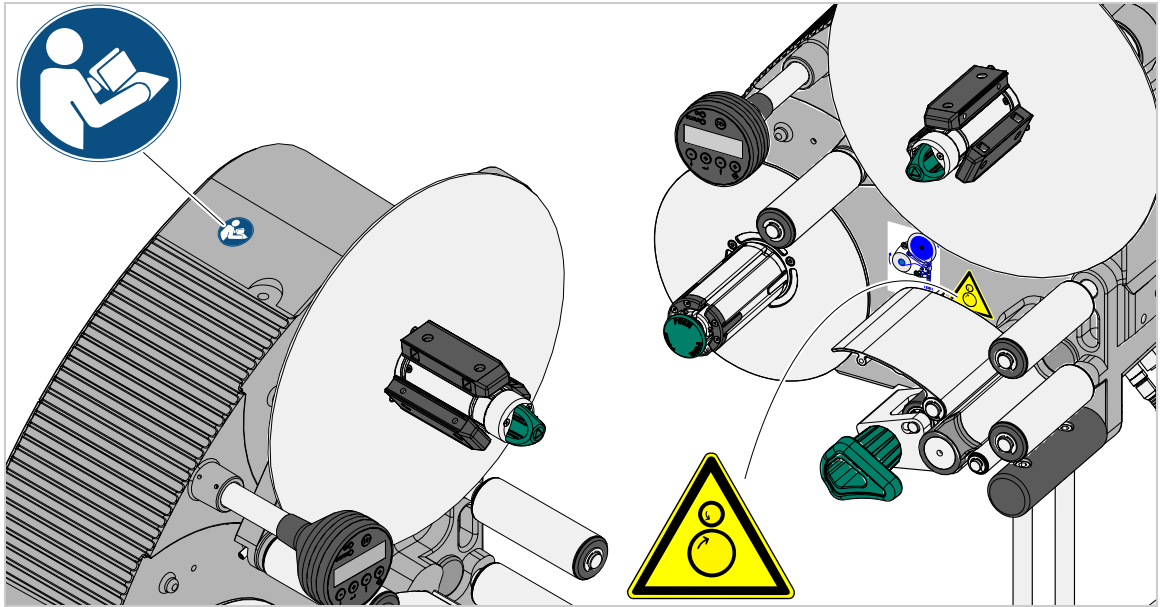
- Do not remove warning notes.
- Replace any missing or illegible warnings.



[1] Position of the warning notes on the machine.

Warning note	Meaning	Article no.
	The 'Pinch Point' warning note warns you of the danger posed by the machine's rotating parts; they can trap items and draw them in.	A5346
	The blue label 'Read manual' demands that users read the unit instructions.	A5331

[Tab. 2] Meaning of the warning notes.

Product description

OVERVIEW

Components

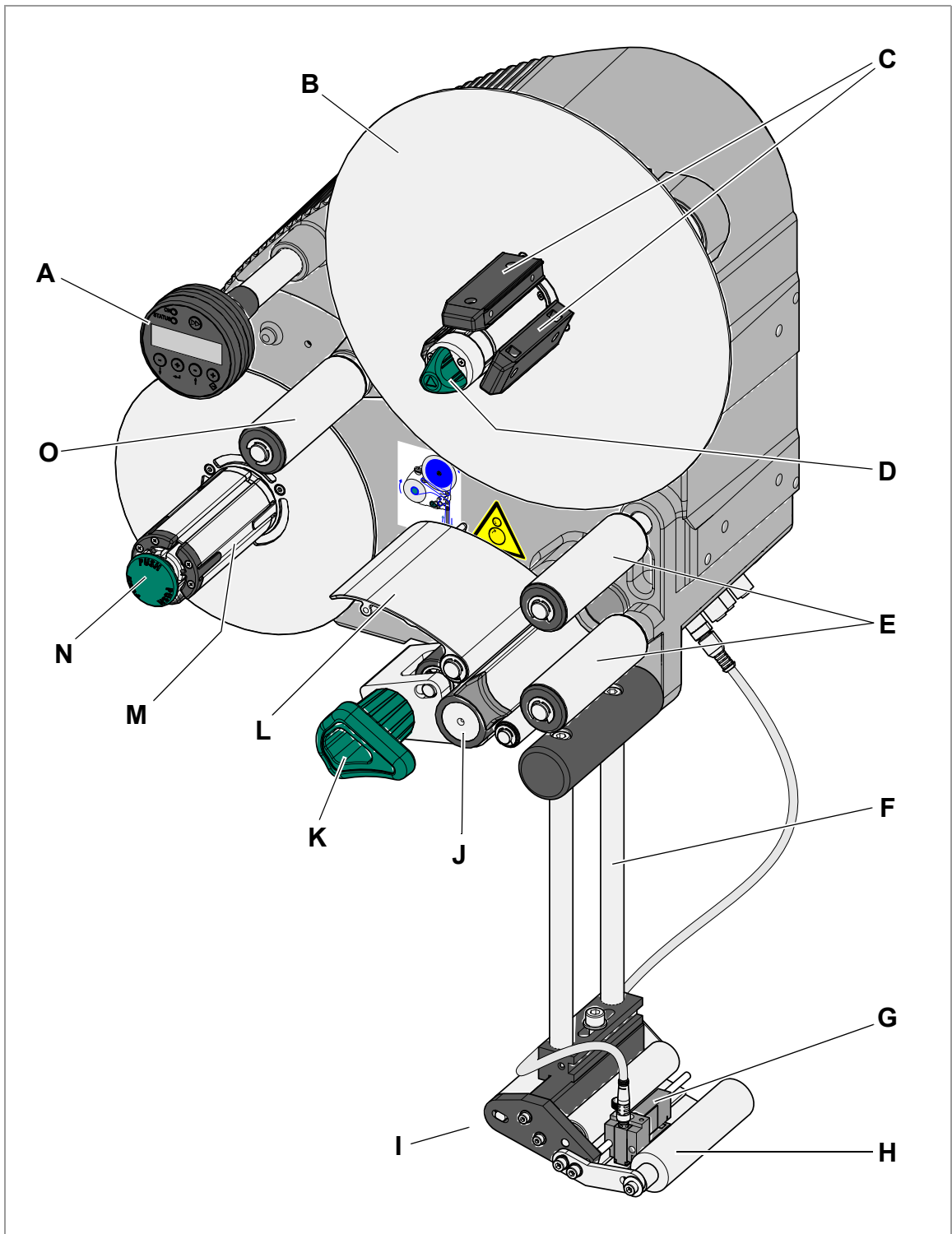

[2] ALS 104 Labeler (right-handed version)

- A** Control panel
 - For sending commands to the device and for displaying operating states and error messages.
 - An optional external control panel can also be connected to the device.
- B** Dispenser
 - Dispenser mandrel grasps the label roll.
- C** Core diameter adapter
 - For adjusting the diameter of the dispenser mandrel to match the core diameter of the label roll.
- D** Adjusting knob
 - Turning this in a clockwise direction secures the label roll on the dispenser.
- E** Deflection rollers
- F** Dispensing edge bracket
- G** Label sensor
 - Stops the label feed after a label has been dispensed
- H** Pressure roller
 - Prints the label once it is stuck to the product
- I** Dispensing edge
 - Standard: (non-adjustable) L-shaped dispensing edge
 - The following options are available: V-shaped dispensing edge, adjustable L-shaped dispensing edge, spring-loaded L-shaped dispensing edge, pneumatic L-shaped dispensing edge
- J** Drive roller
 - Drives the label material forwards
- K** Pressure mechanism
 - Presses the pressure roller against the drive roller
 - Prevents the backing paper from slipping through
 - Releases automatically once the backing paper has been drawn around the drive roller
- L** Tensioning plate
 - Keeps the backing paper taut
- M** Rewinder
 - Rolls up the used backing paper
- N** Release button
 - Pressing this button reduces the diameter of the rewinder core.
 - Allows the easy removal of the rewound backing paper
- O** Dancer arm
 - Keeps the backing paper stretched tight evenly
 - Arrests the rotation of the material roll if tension diminishes

Control panel

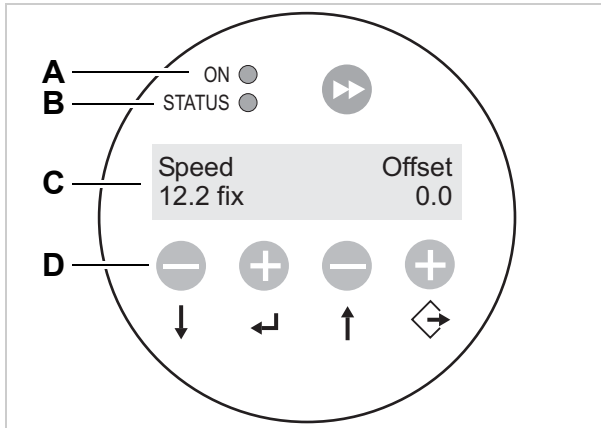

[3] Control panel of the ALS 104
A Operating LED
B Status LED
C LCD display
D Buttons

Operating LED

Lights up green when the device is switched on.

Status LED

LED	Explanation
On	Dispensing mode
Off	Configuration mode
Flashing	Error

[Tab. 3] Meaning of the red status LED

LCD display

- Displays functions, configured values, operating states and error messages
- What is displayed at any one time depends on the operating status of the device; these screens are explained in chapter **Operating modes** on page 27.

Buttons

The button assignments depend on the currently active operating mode and are described in chapter **Operating modes** on page 27.

Connection arrangement

Connections on the back of the device

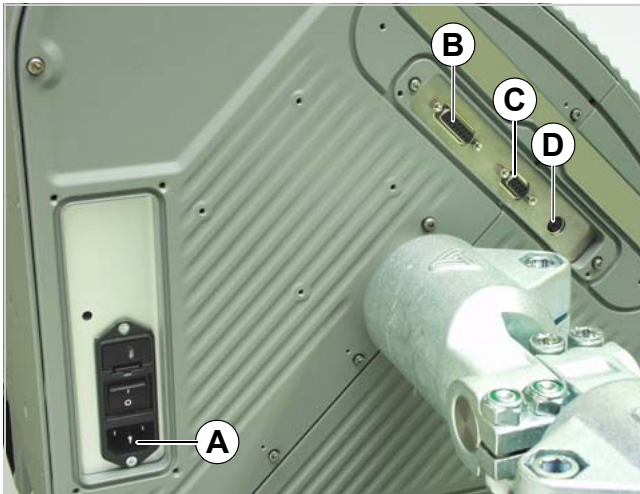

- [4] Connections on the back of the ALS 104:
- A** Power supply connection
 - B** Signal interface (Sub-D15 port)
 - C** RS232 interface (Sub-D9 port)
 - D** Connection for external control panel (PS/2 port)

i Connecting the machine to the mains supply: see chapter [Electrical connections](#) on page 32.

Sensor connections



- [5] Position of the sensor connections on the ALS 104

i Connecting sensors: see chapter [Connecting sensors](#) on page 34.

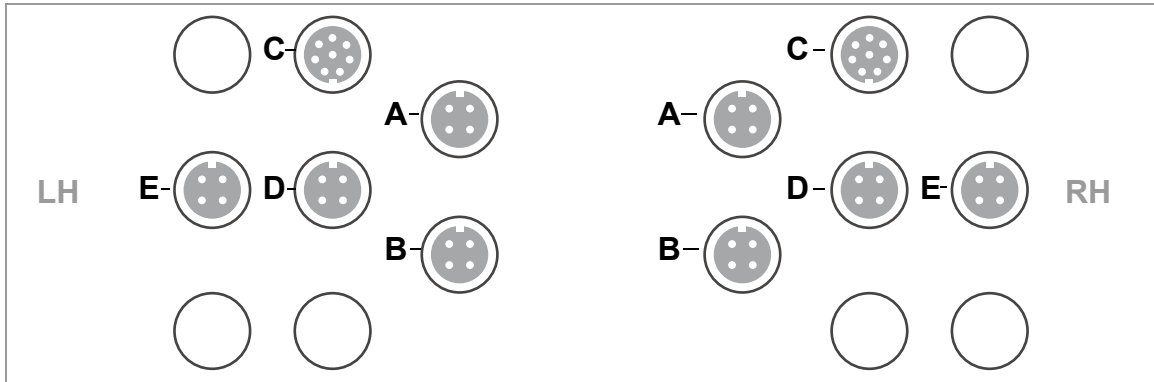

[6] Arrangement of the sensor connections (schematic) on the LH (left figure) and RH (right figure) devices.
A Product sensor
B Label sensor
C Optional: Signal outputs
D Speed sensor (required for automatic speed adaption)
E Roll diameter sensor

Mode of operation

In labelling mode, the strip is first pulled from the label roll around the dancer arm [7A], which consistently maintains even tension in the label strip. The feed roller [7D] behind the dispensing edge [7C] draws the strip across the dispensing plate. The label is unfixed from the backing paper on the dispensing plate and is pressed onto the product with the pressure roller [7B].

The feed roller drives the label strip forwards the length of one label and stops until the next product arrives at the dispensing plate. The feed is started by the product sensor mounted on the conveyor belt. The stop control provided by the label sensor on the dispensing edge ensures the feed is halted as soon as a gap is detected between two labels.

The spent backing paper runs from the dispensing edge around the drive roller [7D], and then over the tensioning plate to be rewound [7E]. The tensioning plate ensures that rewinding is performed evenly.

The entire operation of the labeler is controlled and monitored electronically. If errors occur, the device controls output an appropriate notification for the operator. If necessary, the labelling operating mode is halted automatically. An electronic signal is output at the same time. The signal can be fed to an external controller and evaluated.

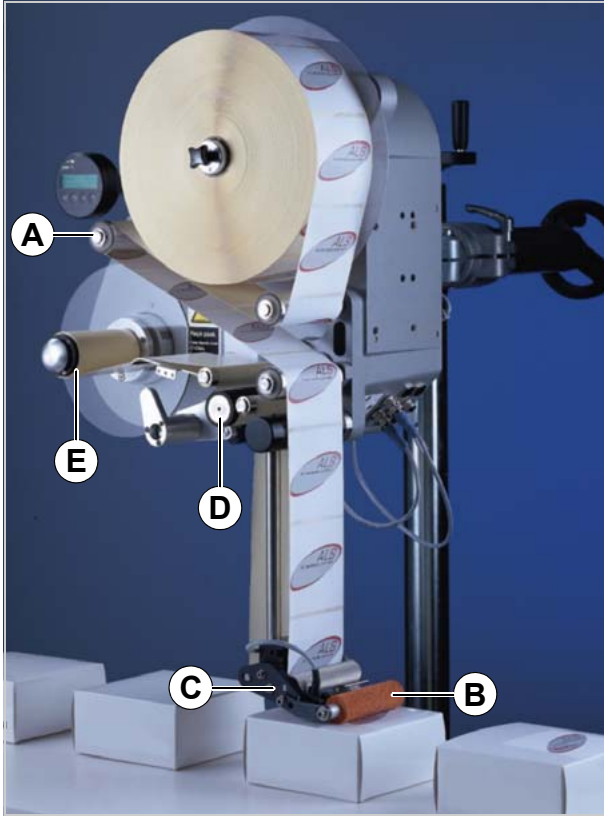

- [7] The ALS 104 is ready for operation in its idle mode.
- A Dancer arm
 - B Pressure roller
 - C Dispensing edge
 - D Drive roller
 - E Rewinder

Design models

The ALS 104 labeler is available in two designs for differing conveyor belt directions.

Right-handed version

- The products are transported from left to right [8 right].
- The dispensing edge is located on the right side.
- Abbreviation: RH

Left-handed version

- The products are transported from right to left [8 left].
- The dispensing edge is located on the left side.
- Abbreviation: LH

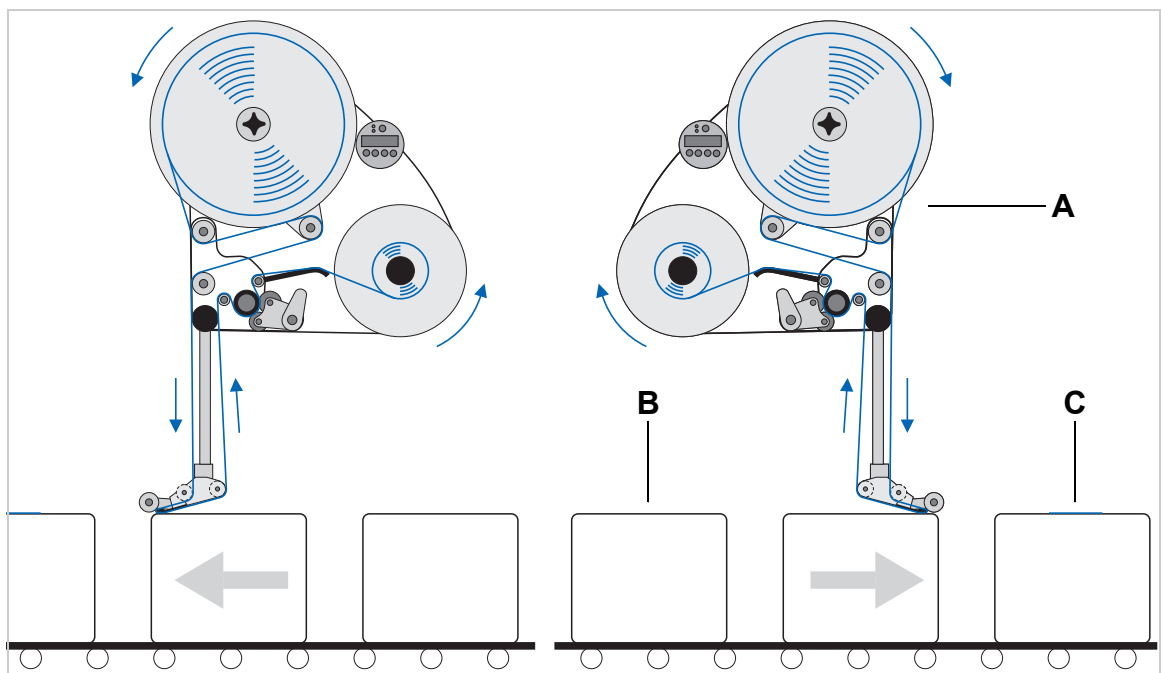

[8] Left: Left-handed version (LH); Right: Right-handed version (RH)
 A ALS 104
 B Product on the conveyor belt
 C Labelled product



The labeler operation described in this manual is based on the right-handed version. The left-handed version is only taken into account if the explanations or figures of the designs differ significantly.

TECHNICAL SPECIFICATIONS

Characteristics

Dispensing speed:	up to 30 m/min
Labelling halt precision ¹ at the peeling edge:	± 0.5 mm
Speed control:	constant speed or automatic speed adaption using speed sensors

1) At a speed range of 5 to 30 m/min

Labels

Label material:	Converted self-adhesive label material with liner
Internal rewinding	yes
Material width (including backing paper) ² :	10 to 110 mm ³
Label length:	5 to 600 mm
Label roll	
Winding direction:	face in or face out
Unwinder (outer) Ø:	up to 300 mm
Rewinder (outer) Ø:	up to 200 mm
Core (inner) Ø:	38.1 / 76.2 / 101.6 mm (1.5 / 3 / 4")

2) Depending on the dispensing edge width.

3) Minimum width for material with PET liner: 30 mm

Label sensor

Distance to peel edge	
L-shape dispensing edge:	19 mm
V-shape dispensing edge (fix):	77 mm
V-shape dispensing edge (variable):	79-207 mm
Sensor type:	Transmission sensor

Power supply

System voltage:	115 V (AC) at 60 Hz power frequency 230 V (AC) at 50 Hz power frequency
Power consumption:	300 VA
Current consumption:	2 A at 115 V system voltage 1 A at 230 V system voltage

Electronics

Processor:	16 Bit DSP
RAM:	4 kB
ROM:	64 kB
Slot for plug-in-cards:	none
Realtime-clock:	none
Control panel:	graphical display with 128 x 32 pixels, 2 lines, 5 buttons
Control panel interface:	RS 422 (Mini DIN 6 connection) for remote control maximum cable length: 10 m
Service interface:	RS232C, D-Sub 9
Sensor interfaces for external sensors (opto-isolated; D-Sub 9 connector, each on a separate 4-pin M12 connector)	
Label sensor:	PNP/NPN ⁴ , 24 V
Product sensor:	PNP/NPN ⁴ , 24 V
APSF-Sensor (Rotary encoder):	single-phase, PNP/ NPN ^{3)/} P-P, 24 V, max. 20 kHz
Outer diameter checking sensor:	PNP/NPN, 24 V
PLC outputs (connection with D-Sub 15 connector, optional with 8-pin M12):	3x PNP, 24 V, max. 500 mA/channel, total permissible output current: 1500 mA One insulated relay output, max. 125 mA (NC/NO), functions parallel to the PNP outputs (selectable) Optional output via an 8-pin M12 connector

4) Selectable by jumper setting

Internal Interfaces

UART for RFID	none
Connector for add motor driver boards	none
Thermal print head connectors	none

Status messages, test functions

Automatic halt, if	... the label roll is spent or no gap was found. ... the maximum allowable number of missing labels has been exceeded.
Test functions:	Automatic diagnostics check when switched on

Dimensions

Height x width x depth: ⁵	492 x 488 x 371 mm
Weight:	33 kg

5) Measurements without the dispensing plate bracket and dispensing plate

Ambient conditions

Installation location:	Inside buildings Protected from wind and spray water Dry Not in areas with potentially explosive atmosphere
Operating temperature:	5 to 40 °C
Humidity:	30 to 85%, (non-condensing)
Noise (at a distance of 1 m):	70 dB(A)
Protection class:	IP 41 IP 65 optional (with extras)
Sea level:	Operation to max. 2000 m above sea level

Integration

Mounting points:	side / bottom / rear
Labelling positions:	top / side / bottom
Dispensing edges:	V-shape L-shape; fixture 90° pivoting, for all L-shape types (4" L-shape disp. edge: material width up to 100 mm only)

Certificates/Markings

- CE, TÜV-Mark, FCC, CCC, EAC, _CTÜV_{US}-Mark
- The *regulation EN 55032* requires for class A devices the following text to be printed in the manual:
„WARNING: This is a class A product. In a domestic environment this product may cause radio interference.“
- The *FCC regulation* requires the following information text for class A products:
„NOTE: This equipment has been tested and found to comply with the limits for a Class A digital device, pursuant to Part 15 of the FCC Rules. These limits are designed to provide reasonable protection against harmful interference when the equipment is operated in a commercial environment. This equipment generates, uses and can radiate radio frequency energy and, if not installed and used in accordance with the instruction manual, may cause harmful interference to radio communications. Operation of this equipment in a residential area is likely to cause harmful interference in which case the user will be required to correct the interference at his own expense“

OPTIONS

External control panel

- An external control panel can be connected in addition to the integrated control panel.
- An external control panel is useful if the standard control panel is inaccessible due to the position in which the unit is installed.



[9] External control panel

Fixed dispensing edge

- The dispensing edge has a fixed connection to the brackets.
- To adjust the vertical position, lift/lower the entire device.
- The slope angle can be adjusted by rotating the brackets (see the service manual for further details).

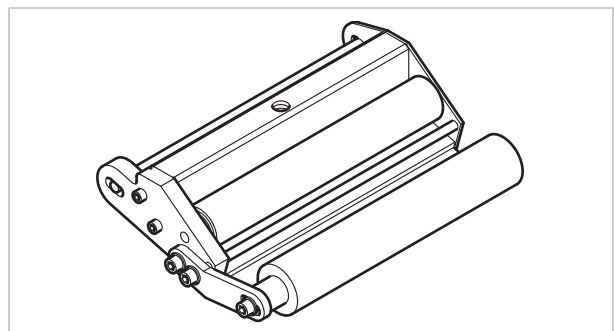

[10] Standard dispensing edge

Swivelling dispensing edge

- The position of the dispensing edge can be adjusted vertically.
- The device need not be moved to adjust the position of the dispensing edge; the device's mounting need not be dismantled.

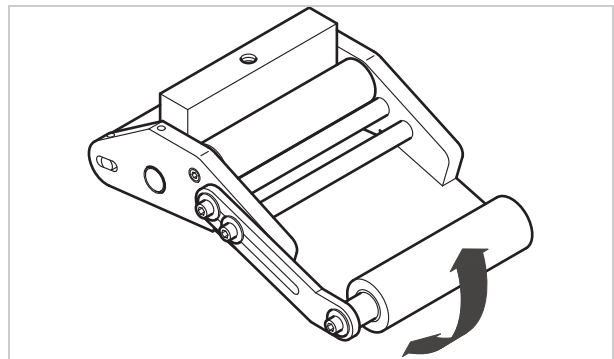

[11] Swivelling dispensing edge

Spring-loaded dispensing edge

- The dispensing edge is pivoted. A torsion spring in the dispensing head presses the dispensing edge downwards and onto the surface of the product.
- Allows compensation for height differences between the products or on the product surface.

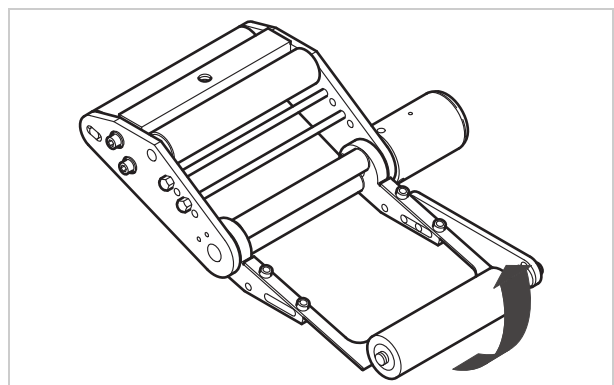

[12] Spring-loaded dispensing edge

Pneumatic dispensing edge

- The dispensing edge is pivoted in the dispensing head. Compressed air presses the dispensing edge onto the surface of the product.
- Allows compensation for height differences between the products or on the product surface.

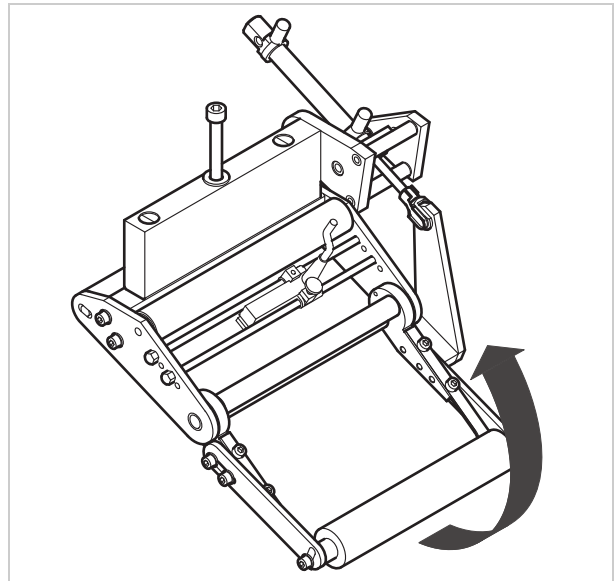

[13] Pneumatic dispensing edge

V-shape dispensing edge

- An alternative for applications which do not leave enough space for the standard dispensing edge holder, which juts out to the bottom side.
- Is attached directly to the machine

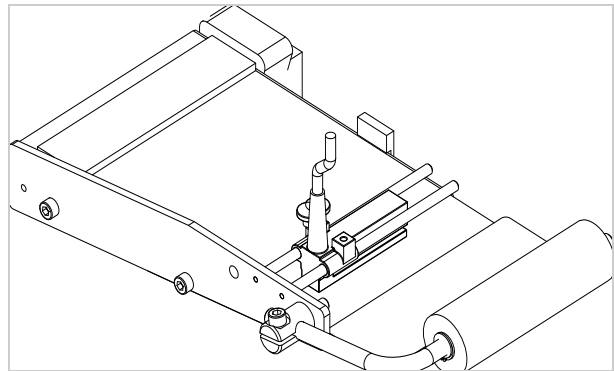

[14] V-shape dispensing edge

Adjustable dispensing edge holder

Enables a vertical fine adjustment of the dispensing edge towards the product without moving the machine.

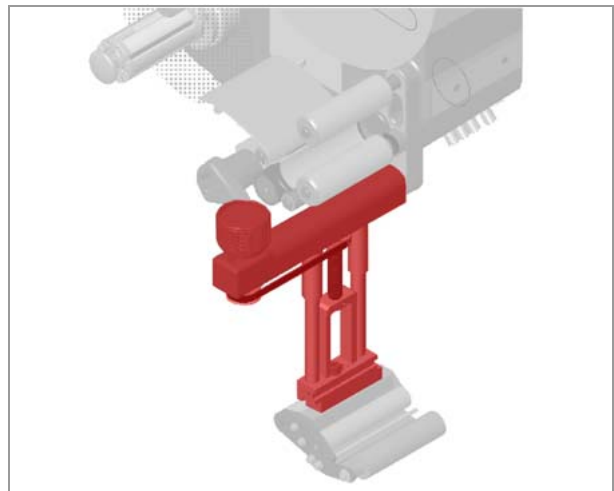

[15] Adjustable dispensing edge holder (pictured red resp. dark gray)

Outer Diameter control sensor

The outer diameter control sensor (OD sensor) triggers a warning, if the label roll outer diameter falls below a certain, adjustable value.

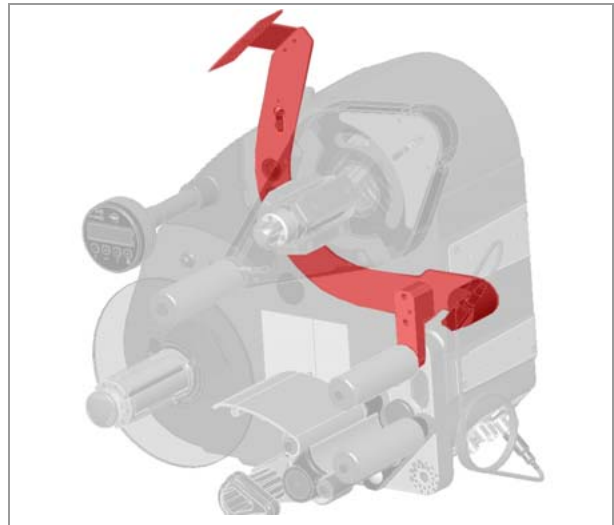

[16] OD sensor (pictured red resp. dark gray)

Dust/Splash guard

Additional sealing of the electrical connections and of the housing fulfils the requirements of the IP65 protection class [16].

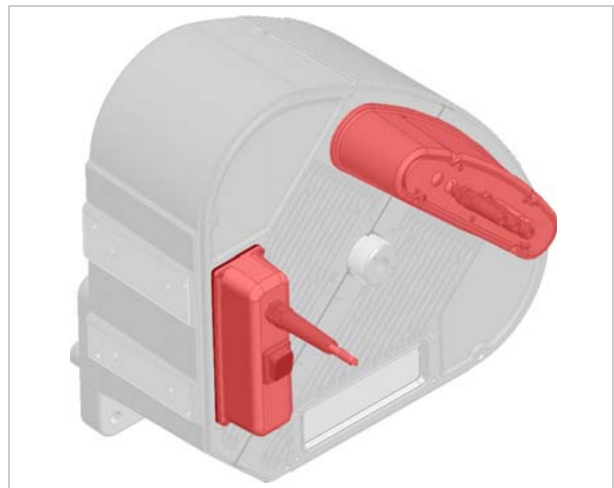

[17] Dust/splash guard of the electrical connections (pictured red resp. dark gray)

Additional material guide disk

The additional material guide disk [18A] improves the lateral guiding of the material roll. This option is especially recommended, if very narrow material (< 30 mm width) is processed.

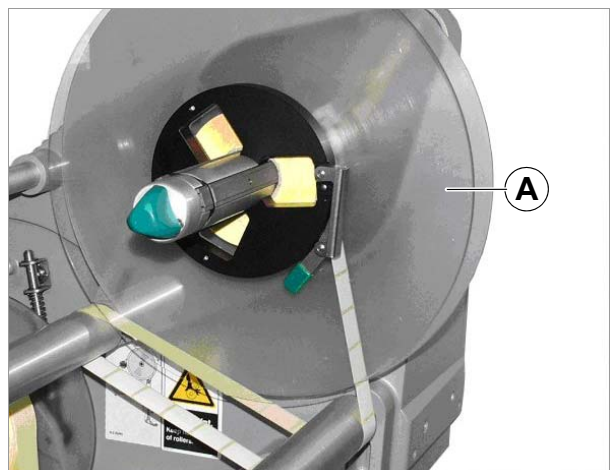

[18] Additional material guide disk (A)

Printer

- If necessary, you can mount a hot stamp printer (not available from Novexx Solutions) onto the holder brackets of the dispensing edge.
- Example of use: Printing consecutive numbers onto labels.

Narrow label spring kit

Narrow label material may under certain circumstances tear off or expand in a way which results in poor labeling precision. In those cases, it is advisable to install weaker dancer arm springs.

OPERATING MODES

Dispensing mode

- This is the operating mode of the unit when switched on.
- The display shows the dispensing speed [19A] and the start offset [19C].
- In dispensing mode, the button assignments are as shown *on the buttons*.
- Both settings can be increased ('+' button) or lowered ('-' button) during dispensing operation [19].
- For more information on adjusting the dispensing operation, see **Function menu settings**  on page 42

Dispensing speed

- Setting range:
 - fix: [5.0...30.0] m/min
 - var: [0.0...30.0] m/min
- Display *fix*: The dispensing speed is constant.
- Display *var*: The dispensing speed adjusts to the speed of the conveyor belt ('speed adaption').

Start offset

- Setting range: [0.0...999.9] mm
- The start offset indicates the distance between the product sensor and the dispensing edge.

Dispensing manually

To manually trigger the dispensing of individual labels:

- Press the button .
- Dispensing speed: As specified in the setting (see above).

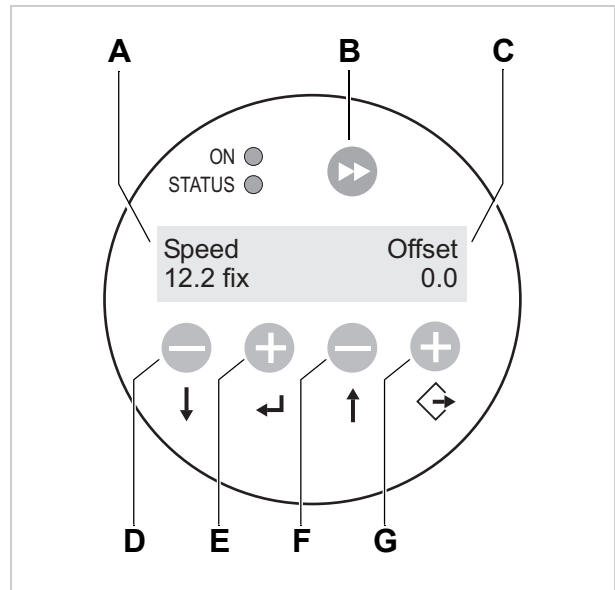

[19] Control panel and button functions in dispensing mode.

- A Dispensing speed display (here: 12.2 m/min)
- B Dispense label button
- C Start offset display (here: 0 mm)
- D Button to lower dispensing speed
- E Button to increase dispensing speed
- F Button to lower start offset
- G Button to increase start offset

Configuration mode

Switching to configuration mode:

→ Press the buttons + .

– Display:

LABEL SETUP

- LABEL SETUP is the name of the first menu shown directly after switching to configuration mode.
- In configuration mode, the button assignments are as shown *below the buttons* [20D].

Function of the double-arrow button

To dispense individual labels:

→ Press button *briefly* (less than two seconds).

- Dispensing speed: As specified in the configuration; ‘Speed Adaption’ is not active.

To automatically calibrate the label length:

→ Hold down the button for a while (more than two seconds).

- Function LABEL SETUP > Label Size is selected.

→ Press the button to activate the function.

Menus

In ‘Configuration’ mode, the user has access to several menus providing a fixed sequence of various functions that can be carried out.

In addition to the LABEL SETUP menu, there are also the menus MACHINE SETUP and SERVICE FUNCTION.

Figure [20] shows the button functions for switching between individual menus and for leaving the configuration mode.

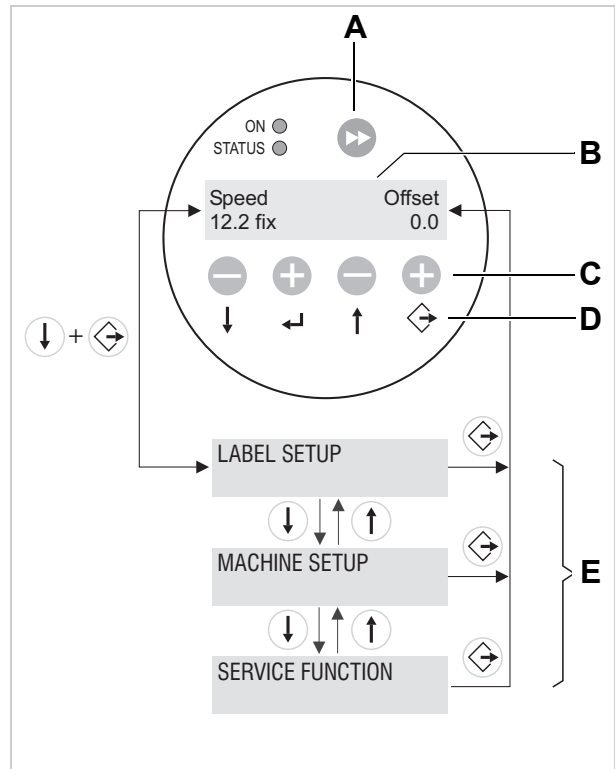

[20] Control panel and button functions in configuration mode.
A Button for triggering a dispensing procedure and for starting the measurement of lengths.
B Display in dispensing mode
C Explanation of buttons in dispensing mode
D Explanation of buttons in configuration mode
E Display indicators in configuration mode

Functions

Every submenu contains functions for setting the unit controls.

Figure [21] shows the buttons functions for changing the configuration with the example of LABEL SETUP > Missing Labels.

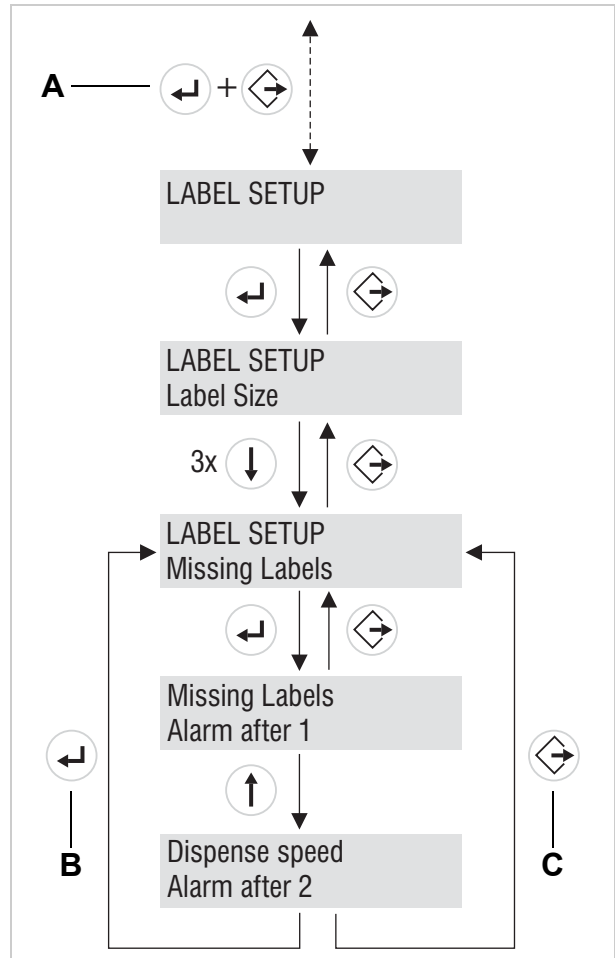

[21] Button functions when using the LABEL SETUP > Missing Labels function.

- A Button combination for 'Switching between configuration and dispensing mode'
- B Button to 'Accept changes'
- C Button to 'Cancel changes'

Function overview

Menus:	LABEL SETUP	MACHINE SETUP	SERVICE FUNCTION ¹
Functions:	Slew Speed	Speed Adaption	Factory Settings
	Label Size	Encoder Resol.	Machine Type
	Stop Sensor Pos.	Encoder Diameter	Offline Behavior
	Product Length		Run continuously
	Missing Labels		Stress test

[Tab. 4] Overview of the menus and functions.

1) The functions in the SERVICE FUNCTIONS menu are password protected.

Function descriptions

LABEL SETUP menu

Function **Slew Speed**

- Speed of feed past missing labels
- Adjustment range [5.0...30.0] m/min



Function **Label Size**

- Automatically calibrates the label length
- Display:

Current Size:
107.7 mm Detect?

- Press  in order to start the calibration; four labels are dispensed during the calibration.
- Display after the calibration:

Size found:
107.7 mm Accept?

-  Press to accept the measured value,
 to quit the function and retain the former value.

Function **Stop Sensor Pos.:**

- Stop sensor position
- Distance between the label sensor (stop sensor) and the dispensing edge
- This setting determines how far out the labels protrude over the dispensing edge when the unit is in its waiting position.
- Setting range: [0.0...999.9] mm

Function **Product Length:**

- Product length
- Prevents the product sensor from being incorrectly activated. Once a product has triggered the sensor, the sensor is locked until the product has passed under the sensor.
- Setting range: [0.0...999.9] mm

Function **Missing Labels:**

- Missing labels
- In practice, sometimes labels are missing from the backing paper. The fault tolerance is defined using the Missing Labels function.
- Set the number of missing labels that must be detected before an error message is triggered.
- Setting range: [1...10]

MACHINE SETUP menuFunction **Speed Adaption**

- Settings: On/Off
- On: The dispensing speed is automatically adjusted to the speed of the conveyor belt; this setting only functions if a rotary encoder is connected.
- Off: The dispensing speed is constant and is as set in dispensing mode (see chapter **Dispensing mode**  on page 27.)

Function **Encoder Resol.**

- Determines the resolution of the rotary encoder.
- Setting range: [10...9999] pulse/revolutions

Function **Encoder Diameter**

- Determines the diameter of the measuring wheel installed with the rotary encoder.
- Setting range: [3.2...318.3] mm
- Display:

Encoder Diameter	
x.x	yy.y var

- The right side (yy.y) shows the speed of the conveyor belt currently measured. By changing the measuring wheel diameter, this value can be adjusted to the actual conveyor speed.

SERVICE FUNCTION menu

Functions for service personnel. For descriptions refer to the service manual.

Before operation

ELECTRICAL CONNECTIONS

Power supply standard machine



WARNING!

This machine operates using mains voltage! Touching live electrical parts may expose you to hazardous electrical currents and may lead to burns.

- Make sure that the unit is switched off before connecting the power cable.
- Only operate the unit with mains voltage set in the fuse insert.
- Ensure that the unit is set to receive the mains voltage supplied by your electricity provider.
- Only connect the unit to a grounded power socket fitted to authorised standards.
- The power cable should not be more than 3 m long.

The device is *only* completely disconnected from the mains if the power cable is unplugged. Therefore:

- Make sure the power supply socket is accessible.
- In case of emergency, switch off the device and disconnect the power cable!

Checking the power supply setting



The ALS 104 is suitable for operation with a power supply of 230 V (AC) or 115 V (AC).

- Make sure that the power cable is disconnected.

ALS 104 with splash guard:

- Turn out the 4 fixing screws [23B] and pull off the hood [23A].
- Check to see that the voltage that has been set conforms to the local mains voltage
 - The set voltage is visible in the display of the fuse insert [23A].



If you are unsure of what mains voltage your local electricity supplier provides, refer to a qualified service technician.



Only a qualified service technician is allowed to change the power supply setting.

You can find further information for performing this operation in the service manual.

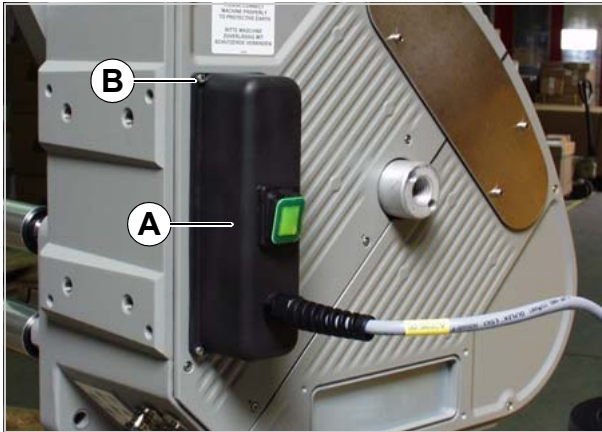

[22] ALS 104 with splash guard.



[23] Voltage display on the fuse insert (showing 230 V here).

Connecting the power cable.

- Ensure that power switch [24A] is set to “O” (off).
- Using the supplied power cable, plug the ALS 104 into a socket connected to the mains supply.



ALS 104 labeler with dust/splash guard option (IP65) may only be connected by qualified service technicians.

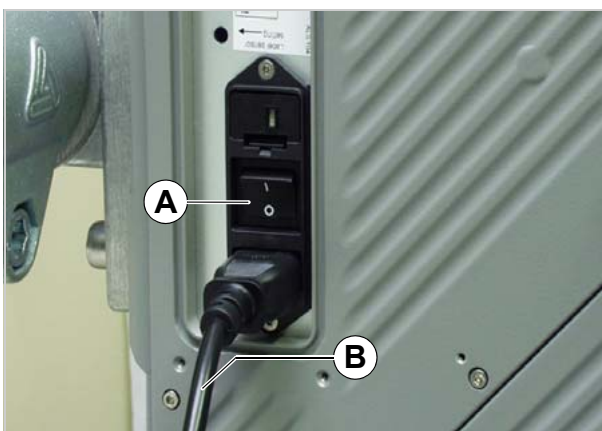

[24] Power cable (B) plugged in.

Connecting sensors



WARNING!

The machine operates using mains voltage! Touching live electrical parts may expose you to hazardous electrical currents and may lead to burns.

→ Only link the unit to devices that fulfil the SELV (safety extra-low voltage) circuit re-quirements specified in EN60950.

→ Check whether the required sensors are connected [25] before turning on the ALS 104.

The minimum required sensors:

- Label sensor (installation location: dispensing edge)
- Product sensor (installation location: conveyor belt)

You have the option of fitting additional sensors as well:

- Speed sensor (required for speed adaption)
- Outer diameter checking sensor (provides advance warning of the end of a label roll)

ALS 104 with splash guard (IP65):

- Not used connectors must be closed with the plugs shipped with the machine.



You can find further information regarding suitable sensor types, pin assignments, and the like in the service manual.

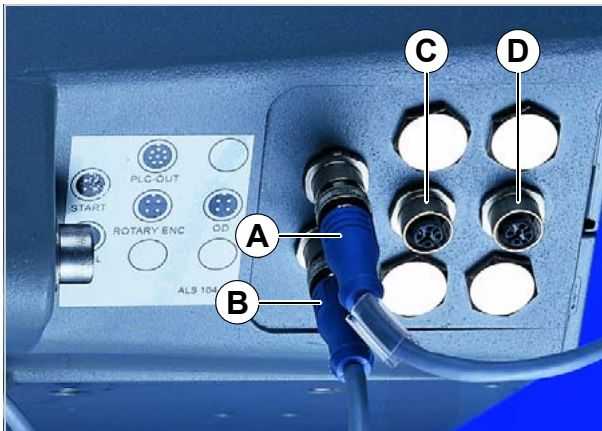

[25] Sensor connectors:

- A** Product sensor
- B** Label sensor
- C** Optional: Speed sensor
- D** Optional: Roll diameter (RD) sensor

INSERTING LABEL MATERIAL

Inserting a label roll



WARNING!

Risk of injury due to moving and rapidly rotating parts!

- Before inserting the label roll, ensure that the device is turned off at the main switch.
- Do not under any circumstances turn the device on before the label strip is threaded in completely.

Danger of injury caused by falling label roll!

- Wear safety shoes.

Removing spent backing paper

Assuming backing paper has gathered on the rewinder [26A] :

- Press the release button [26C].
- The tensioning mechanism of the rewinder is slackened.
- Remove the rewound backing paper.

Removing glue residue

- If necessary, clean the following components:
 - Dispensing plate
 - Deflection rollers
 - Drive rollers
 - Pressure roller
- Follow the directions provided in chapter **Maintenance and cleaning** □ on page 46.

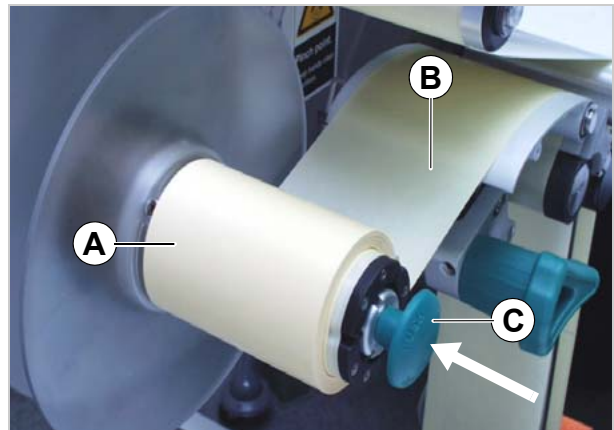

[26] A Rewound backing paper
B Backing paper path
C Release button

Inserting a new label roll

- Push the material roll [27A] onto the unwinder as far as it will go.
- Rotate the rotary knob [27B] in a clockwise direction until the label roll sits tightly.
- Run the label strip around the dancer arm as shown in the figure [27C].
- The material strip must run in a slightly different route when using label rolls with a 'labels facing inwards' winding direction. Insert the roll in such a way that it unwinds in an anticlockwise direction (see **Threading guide** □ on page 36).

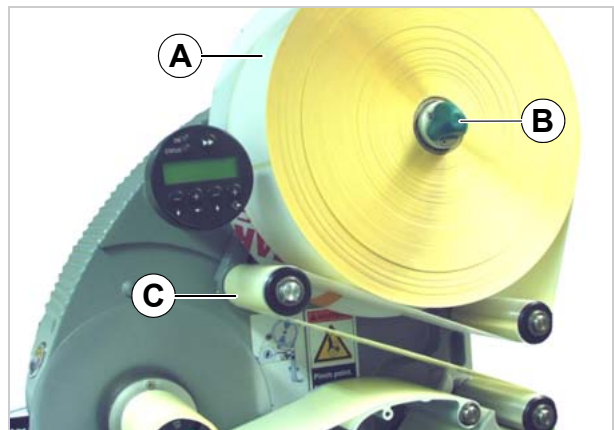

[27] Fasten the label roll to the dispenser (the winding direction of the roll should be with the labels facing outwards).

Threading the label web

Threading guide

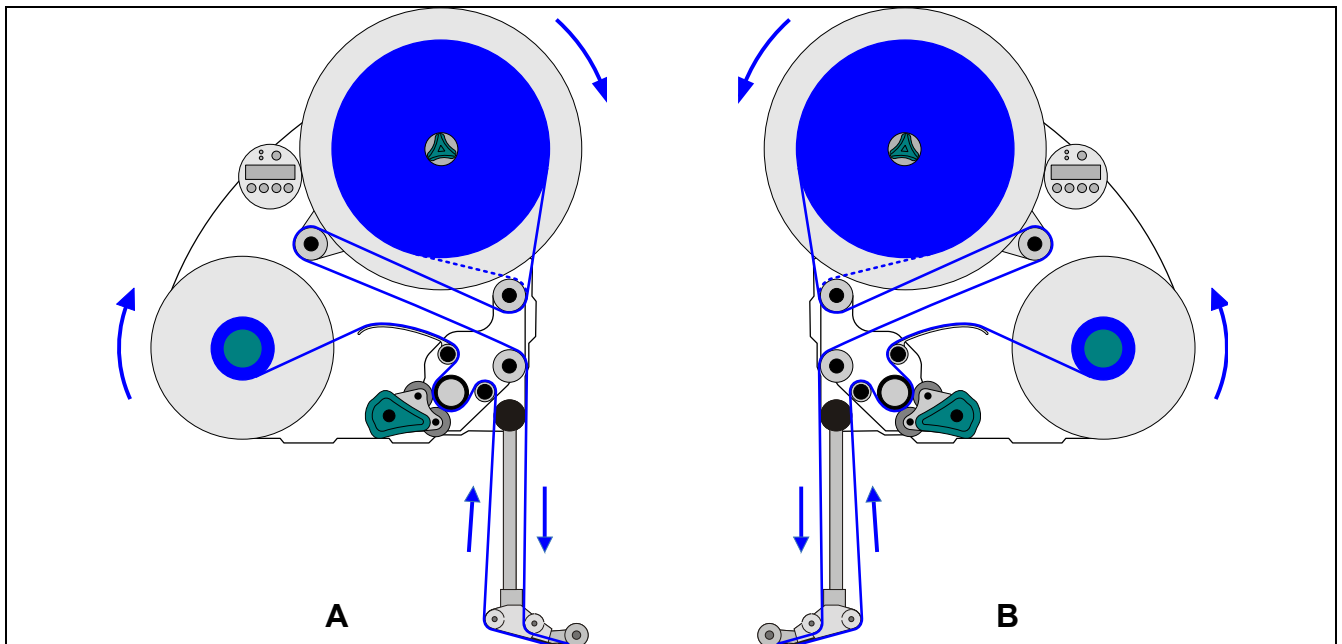

[28] Threading guide for ALS 104 with L-shape dispensing edge *.

- A Right-handed version
- B Left-handed version

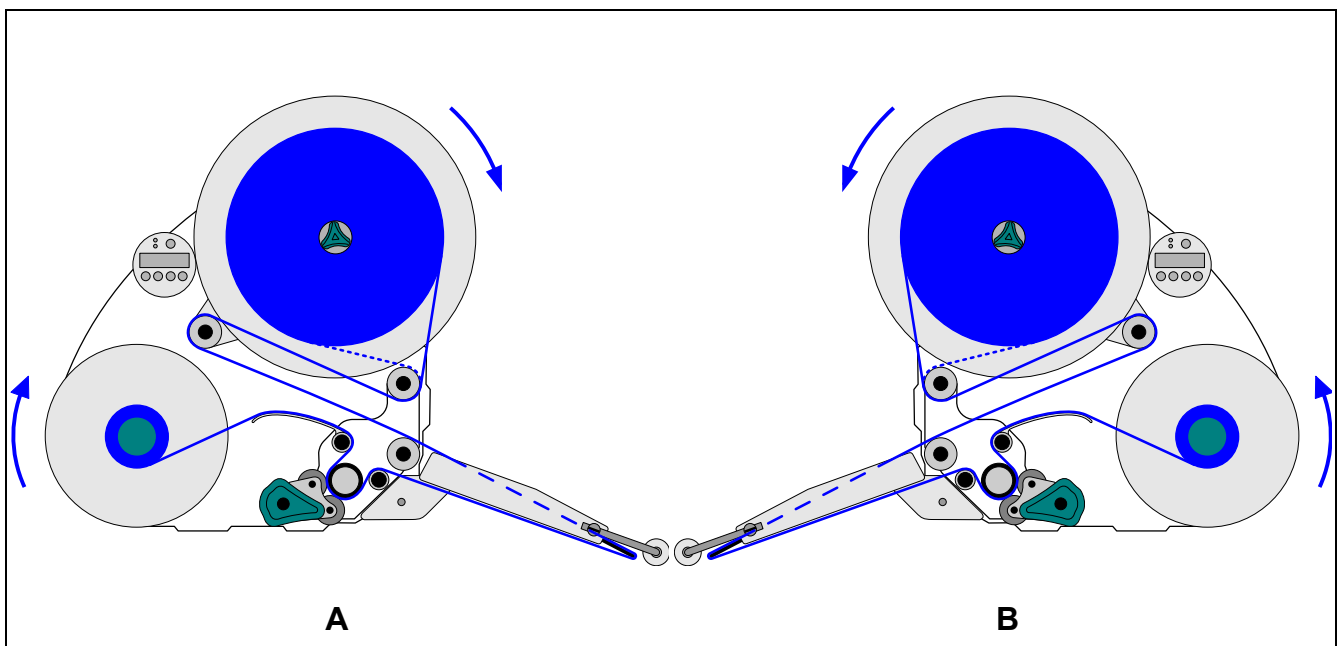

[29] Threading guide for ALS 104 with V-shape dispensing edge *.

- A Right-handed version
- B Left-handed version

*) Solid line: Path for label rolls with labels facing outwards. Dotted line: differing path for label rolls with labels facing inwards.

Threading the label roll at the dispensing edge

- Unroll around 1 m of label strip and remove the labels from it.
- Pass the backing paper around the first deflection roller [30A] and through the slot in the sensor [30B].
- Feed the backing paper under the pressure roller [30C] to the dispensing plate [30D].
- Feed the backing paper around the dispensing plate to the second deflection roller [30E].

Spring loaded [31] and pneumatic [32] L-Shape dispensing edges:

- Additionally pass the backing paper between the two slim deflection rollers at the joint [31A] [32A].

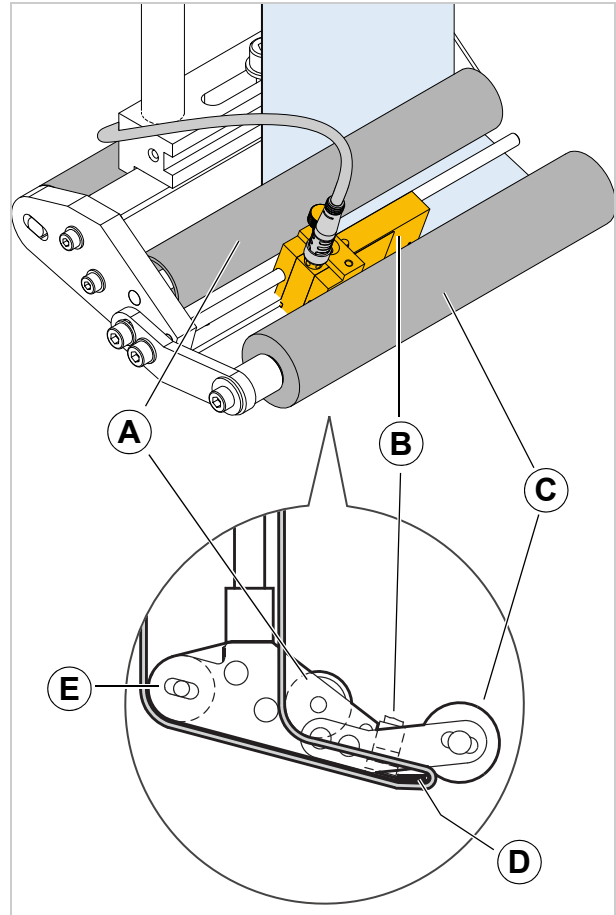

[30] Path of the label strip near the edge of the dispenser.

- A 1st deflection roller
- B Label sensor
- C Pressure roller
- D Dispensing plate
- E 2nd deflection roller

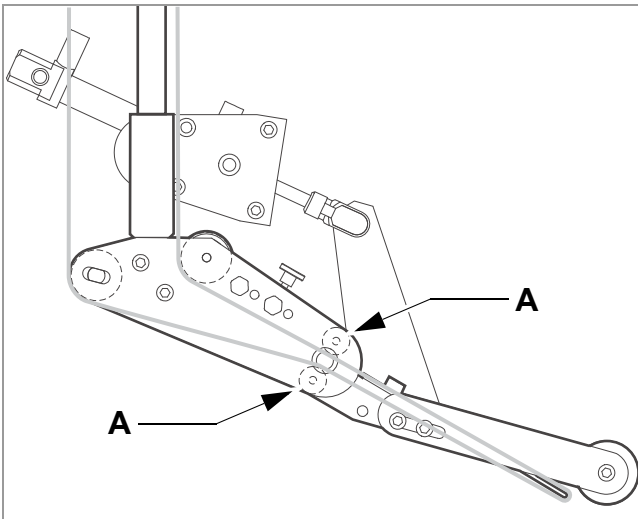

[32] Path of the label strip at the pneumatic dispensing edge (option).

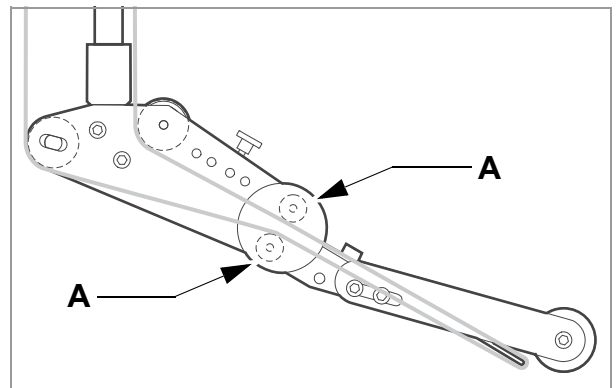

[31] Path of the label strip at the spring loaded dispensing edge (option).

Threading the label roll onto the drive roller

- Open the pressure roller. To do so, rotate the lever [33D] in a clockwise direction.
- Feed the backing paper around the deflection roller [33B], drive roller [33C] and the tensioning plate [33A].
- Close the pressure roller. To do so, rotate the lever anticlockwise until it snaps in noticeably.

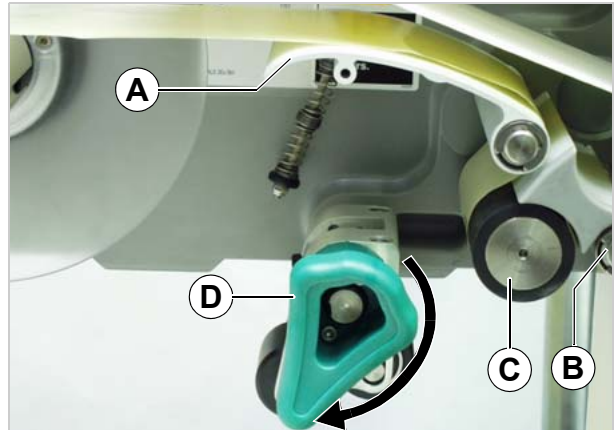

[33] Opening the pressure roller.

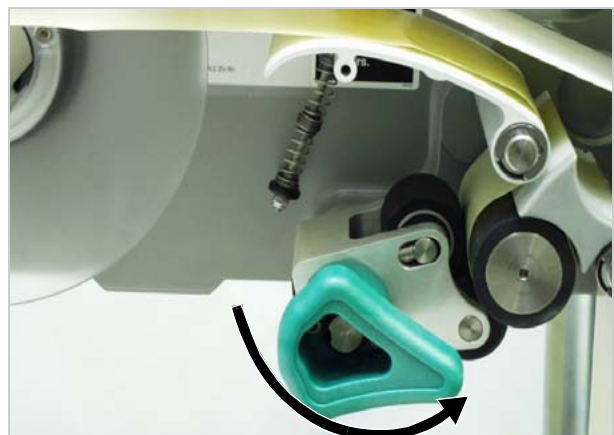

[34] Closing the pressure roller.

Fastening the label roll to the rewinder

- Clamp the backing paper to the rewinder as shown and tighten it [35].



[35] Fastening the backing paper to the rewinder.

MECHANICAL SETTINGS

Adjusting the unwinder's core diameter

- Tool:
- 3 mm hexagon (Allen) screwdriver

The unwinder can be adjusted with core adapters [36B] to fit the inner diameter of the label roll. The adapters must be fitted and dismantled in different ways depending on this diameter:

- 38.1 mm (1") core
- Unscrew the screws [36A] (3 for each adapter) and remove the adapters.
- 76.2 mm (3") core
- Screw on the adapters, as is shown in Figure [36].
- 101.6 mm (4") core
- Screw on the adapters, as is shown in Figure [37].

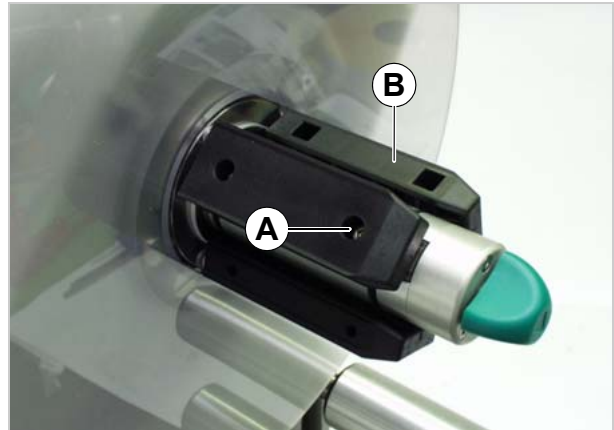

[36] Core adapter position for a core diameter of 76.2 mm.



[37] Core adapter position for a core diameter of 101.6 mm.

Positioning the pressure roller

- Open the pressure roller [38B]. To do so, rotate the lever [38C] in a clockwise direction until the roller snaps up.
- Release thumb screw [38A].
- Align the pressure roller over the backing paper so that it is centred.
- Close the pressure roller.
- Screw the thumb screw tight.

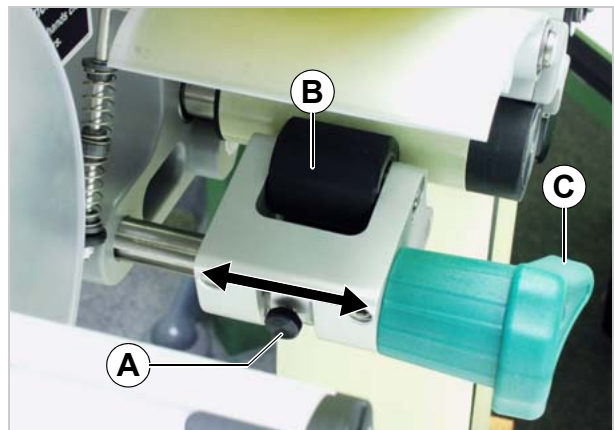

[38] Setting the position of the pressure roller (B).

Calibrating the label sensor

Positioning the sensor:

- Release the thumb screw.
- Position the sensor along the axle in such a way as to allow it to register the spaces between the labels.

Configuring the sensor:

- The settings required for the sensor depend on the employed materials. The standard settings are suitable for many types of label materials.
- Check whether the LED is lit [39A] when the sensor is above a space between labels.
- If this is not the case, the sensor must be configured.
- You should refer to a qualified technician to help configure the sensor.



- Configuration instructions: See the service manual.

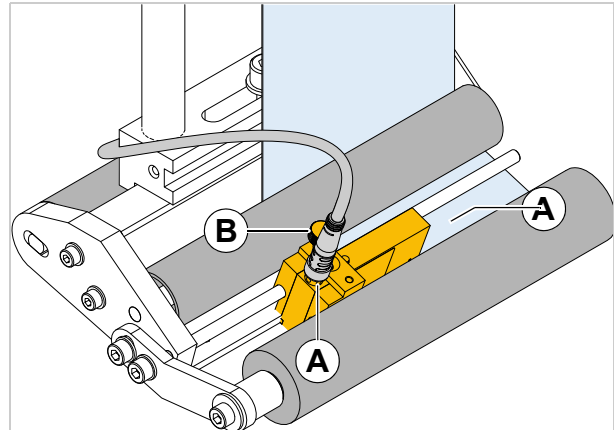

[39] Label sensor at the fixed L-shape dispensing edge.

Setting the dancer arm restoring force

The unwinder dancer arm is preset in a way, that a wide range of label materials can be processed without having to change the dancer arms restoring force.

Even so, very narrow label material can under certain circumstances tear off or expand in a way which results in poor labelling precision. In those cases, the restoring force must be decreased.

Tool:

2.5 mm hex socket screwdriver

- Turn the adjusting screw [40A] on the dancer arm *left* to *increase* restoring force.
- Turn the adjusting screw [40A] on the dancer arm *right* to *decrease* restoring force.



A service technician can restore the factory setting, see service manual chap. 6.2.3 section „Adjusting restoring force of dancer arm“.

If the problem still occurs, although the restoring force is already set to a minimum, there is the option of building in some weaker springs.



The springs must be built in by a qualified service technician. Instructions can be found in the service manual, chap. 6.2.3 section „Narrow label kit“.

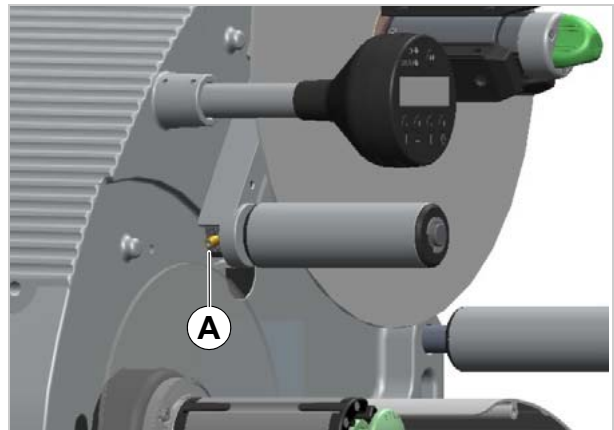

[40] Setting screw (A) at the unwinder dancer arm.

Operation

START-UP AND SHUTDOWN

Turning on the unit

→ Set the main switch [41A] of the unit to 'I' (On).

Machine with dust/splash guard option:

- The main switch [42A] lights, if the machine is switched on.
- Operate the main switch.
- Once on, the ALS 104 is in dispensing mode; in other words, triggering the product sensor will cause a label to be dispensed.
- More information on the dispensing mode can be found in chapter **Dispensing mode** on page 27.

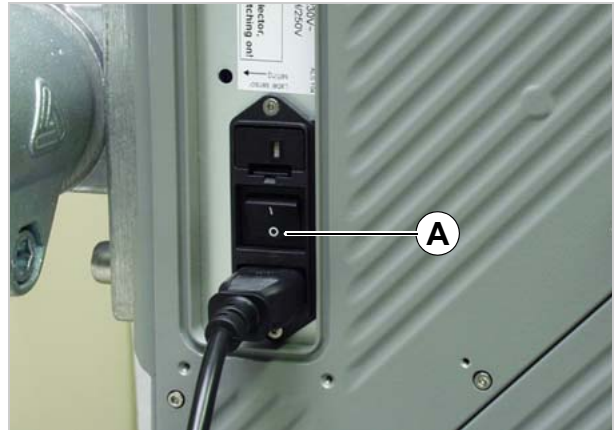

[41] Main switch (A) of ALS 104.

Starting label dispensing

Dispensing with a product sensor

Once switched on, the ALS 104 is in dispensing mode; this means that triggering the product sensor will cause a label to be dispensed.

Prerequisites:

- The label length must be specified
- The product sensor must be connected
- The sensor type (PNP/NPN) must be properly set.



- The sensor type (PNP/NPN) must be properly set.

Dispensing without a product sensor

It is also possible to trigger the dispensing process without a product sensor:

→ Press the key  briefly.

Stopping the dispensing process

→ Set the main switch [41A] of the unit to 'O' (Off).



[42] Mains switch (A) of ALS 104 with dust/splash guard option.

CONFIGURATION AND MONITORING

Function menu settings

Label length

The label length is calibrated automatically.

Prerequisites:

- Label material is inserted
- Call up the function LABEL SETUP > Label Size:

Current Size:	
0.0 mm	Detect?

- Press the key  to start the calibration. ALS 104 then dispenses four labels in order to determine their length:

Size Found:	
107.7 mm	Accept?

- Press the key  to accept the calibrated value, or press  to retain the old value.

Label stop position

Prerequisites:

- The label length must be specified

The next label to be dispensed is halted in the label stop position. This is useful if the label protrudes over the dispensing edge somewhat [43].



ALS 104 is pre-configured for use with the supplied label sensor. If this sensor is employed, the label stop position setting will only require minimal correction.

Correcting the default setting:

- Call up LABEL SETUP > Stop sensor pos..
- Increase the value to increase the overhang or lower the value to reduce the overhang.

The value '0' will cause the label to stop directly with its front edge under the label sensor.

The front edge of the label to be dispensed should be flush with the dispensing edge:

- Enter the distance [43A] between the label sensor and the dispensing edge.

The front edge of the label to be dispensed should overhang:

- Add the length of the overhang to the distance between the label sensor and the dispensing edge.

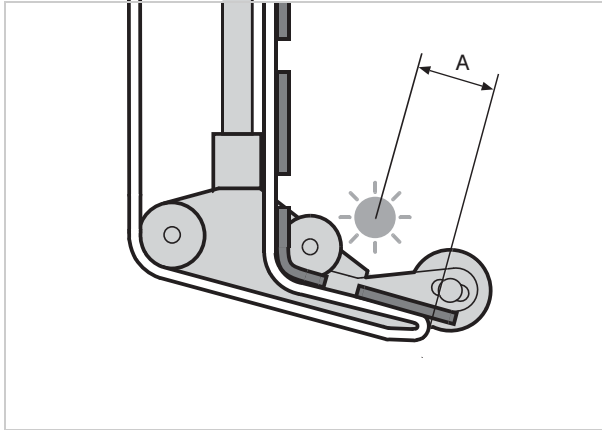

[43] Label stop position (A)

Dispensing speed

The dispensing speed can be set to a fixed value or can be configured to automatically adjust to the speed of the conveyor belt (speed adaption). The second possibility requires a speed sensor to be connected; it measures and relays the conveyor speed to the dispenser.

Configuring a *fixed value*:

→ Set the speed in dispensing mode with the two left keys (see **Dispensing mode**  on page 27).

Configuring *speed adaption*:

→ Turn the function on by setting MACHINE SETUP > Speed Adaption to 'On'.



→ MACHINE SETUP > Encoder Resol. and
MACHINE SETUP > Encoder Diameter set as appropriate for the employed speed sensor.

– See the service manual for information on suitable speed sensors.

Label position on the product

Prerequisites:

- The label length must be specified.
- The label stop position must be set.

The *Start Offset* is set in dispensing mode with the right two keys (see **Dispensing mode**  on page 27).

- The label should be flush with the front edge of the product:
→ Enter the distance between the product sensor and the label sensor [44A].

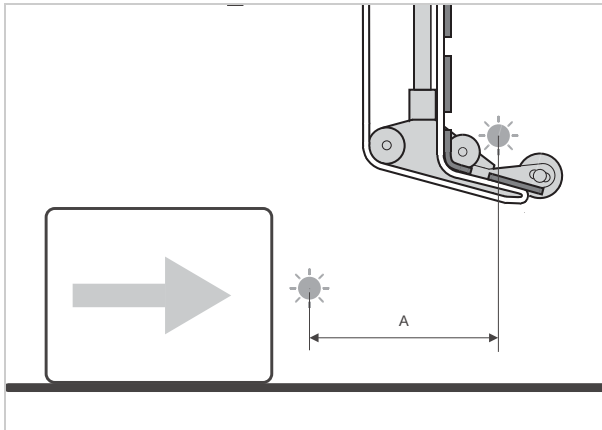

[44] Distance between the product sensor (left) and the label sensor (right).

- The label should stop at a distance from the front edge of the product:
→ Increase the start offset [45A] to increase the distance to the product's front edge.

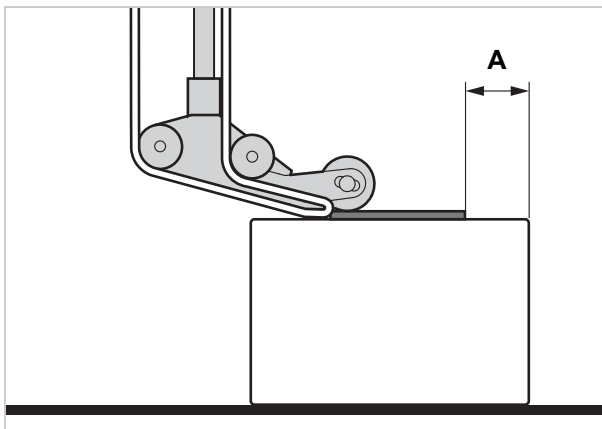

[45] Distance (A) between the label and the product's front edge.

Monitoring functions

While in dispensing mode, an electronic control monitors the following functions:

Missing labels

A label missing from the label roll does not normally affect the dispensing operation, because the label feed continues until a label's edge passes under the label sensor.

Nonetheless, it can be important that missing labels are reported. By configuring the function LABEL SETUP >Missing Labels, you can specify whether an error message is triggered after one or several missing labels.

Recognising the end of the label roll in advance

If the end of the label roll is to be recognised prior to the last label being dispensed, it is recommended that a sensor is used to check the outer diameter of the roll.

This sensor, which is available as an extra, is mounted on the unit in such a way as to trigger an error message as soon as the roll's diameter falls short of a specified value. This diameter can be configured.

After operation

MAINTENANCE AND CLEANING

Changing fuses



WARNING!

The machine operates using mains voltage! Touching live electrical parts may expose you to hazardous electrical currents and may lead to burns.

→ Make sure that the machine is switched off and the power cable is unplugged before removing the fuse insert.

CAUTION!

Risk of fire, if a wrong fuse type is inserted.

→ Only replace fuses with the type and rating specified in this manual.



ALS 104 with dust/splash guard: Fuses may only be replaced by qualified service technicians.

- Turn off the unit. Unplug the power cable.
- Remove the fuse insert. To do this, press the latch upwards [46A] and pull out the insert [47A].
- The fuse insert is located directly above the On/Off switch.

- Take the fuses out of the fuse insert.
- Replace defective fuses.



Required fuse type:

- 2x F5AH / 250 V
- The same fuse type is required for 230 V as for 115 V.
- The fuses must conform to IEC 60127-2/5 (for example, "Wickmann 181 Series")



[46] Unlock the fuse insert.



[47] Remove the fuse insert (A).



[48] Remove (A) fuses.

Cleaning agents



Cleaning agents for rubber rollers [49A]:

- Roller cleaner, order number 98925.
If other cleaning agents are used, there is a chance the rubber may corrode.

Cleaning agents for metal deflection rollers [49B]:

- Cleaning solvent, alcohol-based solvent, isopropyl alcohol, spray for removing labels

Cleaning the unit's housing:

- Commercially available neutral cleaning liquid

CAUTION!

Unsuitable cleaning agents can cause considerable damage to the unit!

→ Do not use any cleaning agent that could damage or destroy the resin surface, labelling, display, nameplates, electrical components, etc. Observe the instructions of the cleaning agent manufacturer.

→ Do not use any abrasive or plastic-corroding cleaning agents.

→ Do not use any acidic or alkaline solutions.

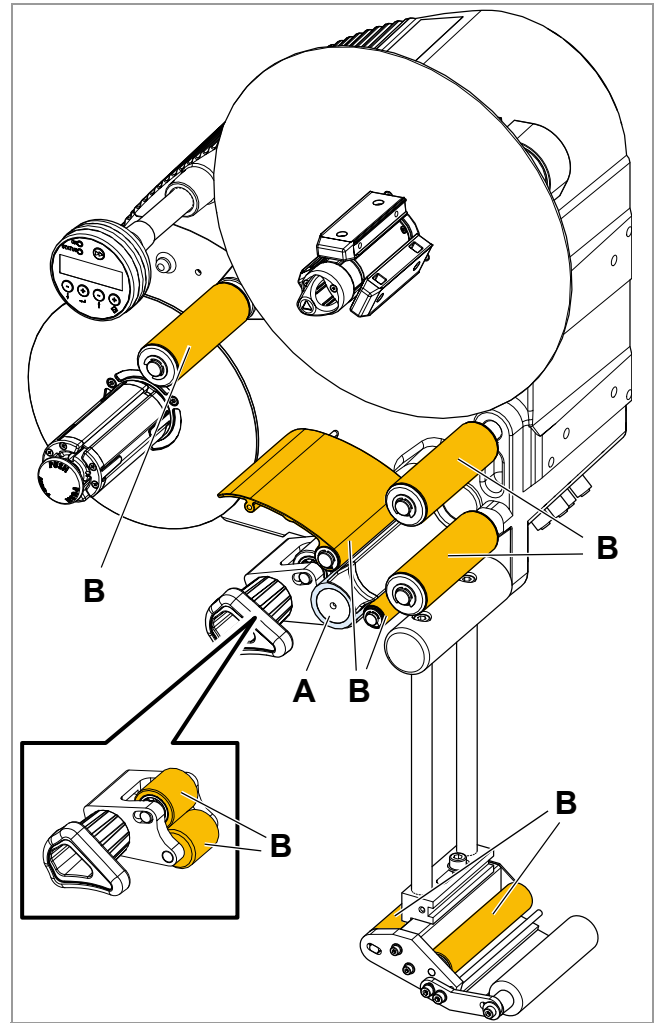

[49] Rollers at the ALS 104:
A Rubber rollers
B Metal deflection rollers

Regular maintenance

The labeler is designed to be maintenance-free. However, you should service the unit regularly in order to ensure reliable long-term operating results.

Depending on operating conditions, you should perform the following at least on a weekly basis:

→ The cleaning and maintenance work described below.

Removing paper debris

→ Wipe the paper residue from the rollers and edges.

→ Clean the sensor lenses with a soft brush or cloth.

Deflexion rollers

Glue from the label material may adhere to the deflexion rollers.

→ Moisten a clean cloth with cleaning solvent and wipe off the dirty deflexion rollers [49B] with it.

Rubber rollers

Glue from the label material may adhere to the rubber rollers.

→ Moisten a clean cloth with roller cleaner and wipe off the dirty rubber rollers [49A] with it.

Operational failures

ERROR MESSAGES

Error messaging

Error messages are displayed as follows:



xxxxxxxxxxxxxxxxxxxx = Message text

At the same time, a signal is activated at the signal output of the unit, which can be used to switch on an external visual or audible signal.

→ Press the key to reset the error message.

Before considering applying any remedies, check whether the message appears repeatedly:

- Turn off the unit and switch it on again after 10 seconds.
- It is important to wait at least 10 seconds before switching the unit back on again.

List of error messages

No.	Message text	Possible cause	Remedy
1	General Alarm	<ul style="list-style-type: none"> – Motor failure – Motherboard malfunction 	→ Request a service technician
3	Missing Label	Max. number of missing label was exceeded	→ Check the label material
4	Material Low	Without a connected roll diameter check: <ul style="list-style-type: none"> – The product sensor may have been mistakenly connected to the socket for the roll diameter check. – Internal sensor connection cables may be mixed up. With a connected roll diameter check: <ul style="list-style-type: none"> – The material roll has fallen short of the critical diameter. 	→ Connect the product sensor to the correct socket. → Request a service technician. → Prepare to change the material roll.
5	Unknown Length	The function LABEL SETUP > Label Size was cancelled unsuccessfully. <ul style="list-style-type: none"> – No label material inserted. – Electronic fault. 	→ Insert label material. → Request a service technician.

[Tab. 5] Overview of numbered error messages.

EU Declarations

EU DECLARATION OF CONFORMITY

(Translation of original version)

We,

Novexx Solutions GmbH
 Ohmstraße 3
 D-85386 Eching
 Germany

hereby declare that we have designed and built the machine designated below so that it is in conformity with the basic safety and health protection requirements of the directive named below:

Models	ALS 104
General designation	Labeler
Applicable EU directive	2014/30/EU (EMC) 2011/65/EU (RoHS)
Applied harmonized standards, especially	EN 55032 : 2012 class A EN 61000-6-2 : 2005 EN 61000-3-2 : 2014 EN 61000-3-3 : 2013

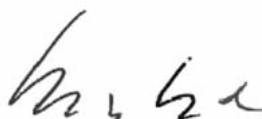

Manfred Borbe (Director)

Eching, 1.8.2017

EU DECLARATION OF INCORPORATION

(Translation of original version)

We, Novexx Solutions GmbH
 Ohmstraße 3
 D-85386 Eching
 Germany

hereby declare that the partly completed machine designated below has been designed and built in such a way as to be in conformity with the safety and health protection requirements of directive 2006/42/EC, annex I, which are marked „fulfilled“ in the following table „Appendix regarding the Declaration of Incorporation“.

The special technical documents in accordance with appendix VII part B of directive 2006/42/EC have been created. We undertake to forward the special technical documentation in respect of the partly completed machine to national authorities at their request. We shall submit them by means of electronic data carrier.

The partly completed machine designated herein is furthermore in compliance with the provisions of directive 2014/30/EU (EMC) and directive 2011/65/EU (RoHS).

The designated partly completed machine must not be placed in operation until it has been determined that the machine in which the partly completed machine has been installed is in compliance with the provisions of directive 2006/42/EG.

Models	ALS 104
General designation	Labeler
Applicable EU directive	2006/42/EC (Machinery Directive)
Applied harmonized standards, especially	EN ISO 12100 : 2010 EN 415-2:1999 EN 60950-1 : 2006/A2 : 2013
The person authorized to compile technical documents	Novexx Solutions GmbH (for address see above)

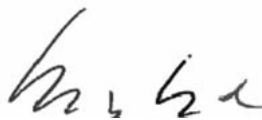

Manfred Borbe (Director)

Eching, 1.8.2017

APPENDIX REGARDING THE DECLARATION OF INCORPORATION

List of the essential health and safety requirements applied and fulfilled for the product named in the declaration of incorporation, relating to the design and construction of machinery.

Number Annex I	Designation	Not applicable	Fulfilled	Remark
1.1	General remarks			
1.1.2.	Principles of safety integration		X	
1.1.3.	Materials and products		X	
1.1.4.	Lighting	X		
1.1.5.	Design of machinery to facilitate its handling		X	
1.1.6.	Ergonomics		X	
1.1.7.	Operating positions	X		
1.1.8.	Seating	X		
1.2.	Control systems			
1.2.1.	Safety and reliability of control systems		X	
1.2.2.	Control devices		X	
1.2.3.	Starting		X	
1.2.4.	Stopping			
1.2.4.1.	Normal stop		X	
1.2.4.2.	Operational stop	X		
1.2.4.3.	Emergency stop		X	
1.2.4.4.	Assembly of machinery	X		
1.2.5.	Selection of control or operating modes	X		
1.2.6.	Failure of the power supply		X	
1.3.	Protection against mechanical hazards			
1.3.1.	Risk of loss of stability		X	
1.3.2.	Risk of break-up during operation		X	
1.3.3.	Risks due to falling or ejected objects		X	
1.3.4.	Risks due to surfaces, edges or angles		X	
1.3.5.	Risks related to combined machinery	X		
1.3.6.	Risks related to variations in operating conditions	X		
1.3.7.	Risks related to moving parts		X	
1.3.8.	Choice of protection against risks arising from moving parts			
1.3.8.1.	Moving transmission parts		X	
1.3.8.2.	Moving parts involved in the process			Requires protective device ^a
1.3.9.	Risks of uncontrolled movements	X		
1.4.	Required characteristics of guards and protective devices			
1.4.1.	General requirements			a
1.4.2.	Special requirements for guards			
1.4.2.1.	Fixed guards	X		
1.4.2.2.	Interlocking movable guards			a
1.4.2.3.	Adjustable guards restricting access	X		
1.4.3.	Special requirements for protective devices	X		
1.5.	Risks due to other hazards			
1.5.1.	Electricity supply		X	
1.5.2.	Static electricity		X	
1.5.3.	Energy supply other than electricity		X	

Number Annex I	Designation	Not applicable	Fulfilled	Remark
1.5.4.	Errors of fitting		X	
1.5.5.	Extreme temperatures		X	
1.5.6.	Fire		X	
1.5.7.	Explosion	X		
1.5.8.	Noise		X	
1.5.9.	Vibrations	X		
1.5.10.	Radiation		X	
1.5.11.	External radiation		X	
1.5.12.	Laser radiation	X		
1.5.13.	Emissions of hazardous materials and substances	X		
1.5.14.	Risk of being trapped in a machine	X		
1.5.15.	Risk of slipping, tripping or falling	X		
1.5.16.	Lightning	X		
1.6.	Maintenance			
1.6.1.	Machinery maintenance		X	
1.6.2.	Access to operating positions and servicing points		X	
1.6.3.	Isolation of energy sources		X	
1.6.4.	Operator intervention		X	
1.6.5.	Cleaning of internal parts	X		
1.7.	Information			
1.7.1.	Information and warnings on the machinery		X	
1.7.1.1.	Information and information devices	X		
1.7.1.2.	Warning devices	X		
1.7.2.	Warning or residual risks		X	
1.7.3.	Marking of machinery		X	
1.7.4.	Instructions		X	
1.7.4.1.	General principles for the drafting of instructions		X	
1.7.4.2.	Contents of the instructions		X	
1.7.4.3.	Sales literature		X	

a) Installation by the system integrator

Novexx Solutions GmbH
Ohmstraße 3
85386 Eching
Germany
☎ +49-8165-925-0
www.novexx.com

NOVEXX 
SOLUTIONS